

POWER-GATE™ Solid-State Devices

OR'ing Non-Programmable

Specification Sheet

Generation 4.1

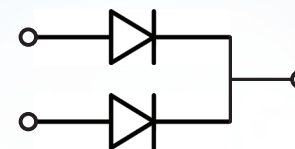

ABSOLUTE MAXIMUM RATINGS⁽¹⁾

All devices ("x" = don't care) , all amperages DC, all voltages DC and referenced to device ground, "y" = 1(2) for anode 1(2) terminal, respectively, or unless otherwise specified.

Symbol	Parameter	Min.	Max.	Units
V _{KA}	Cathode-to-Anode Voltage, Devices ORx41A-xxx		21 ⁽²⁾	V
	Cathode-to-Anode Voltage, Devices ORx41B-xxx		39 ⁽³⁾	V
V _{KK}	Cathode-to-Cathode Voltage, Devices ORx41A-xxx		21 ⁽²⁾	V
	Cathode-to-Cathode Voltage, Devices ORx41B-xxx		39 ⁽³⁾	V
V _{Ay}	Anode Voltage, Devices ORx41A-xxx	-21 ^(4,6)	21 ^(2,6)	V
	Anode Voltage, Devices ORx41B-xxx	-39 ^(5,6)	39 ^(3,6)	V
V _K	Cathode Voltage, Devices ORx41A-xxx	-21 ^(4,6)	21 ^(2,6)	V
	Cathode Voltage, Devices ORx41B-xxx	-39 ^(5,6)	39 ^(3,6)	V
I _{F,gnfloat} ⁽⁷⁾	Forward Current (per rectifier, ground floating), Devices ORM41x-100		10	A
	Forward Current (per rectifier, ground floating), Devices ORM41x-150		15	A
	Forward Current (per rectifier, ground floating), Devices ORM41x-200		20	A
	Forward Current (per rectifier, ground floating), Devices ORM41x-250		25	A
	Forward Current (per rectifier, ground floating), Devices ORM41x-300		30	A
	Forward Current (per rectifier, ground floating), Devices ORL41x-400		40	A
	Forward Current (per rectifier, ground floating), Devices ORL41x-500		50	A
	Forward Current (per rectifier, ground floating), Devices ORL41x-600		60	A
T _A	Ambient Temperature	-45	+90	°C
I _{STAT,MAX}	Remote Status Maximum Sink Current		50	mA
V _{STAT(OFF),MAX}	Remote Status Maximum Off Voltage	-60	60	V

RECOMMENDED OPERATING CONDITIONS

All devices ("x" = don't care) , all amperages DC, all voltages DC and referenced to device ground, "y" = 1(2) for anode 1(2) terminal, respectively, or unless otherwise specified.

Symbol	Parameter	Min.	Max.	Units
V _{Ay}	Anode Voltage, Devices ORx41A-xxx	5.6	18	V
	Anode Voltage, Devices ORx41B-xxx	5.6	36	V
V _K	Cathode Voltage (anode voltage at min.), Devices ORx41A-xxx	5.5	18	V
	Cathode Voltage (anode voltage at min.), Devices ORx41B-xxx	5.5	36	V
T _A	Ambient Temperature	-40	+85	°C

ELECTRICAL SPECIFICATIONS

All devices ("x" = don't care), all amperages DC, all voltages DC and referenced to ground, "I_F" = rectifier forward current, "y" = 1(2) for anode 1(2) terminal, respectively, T_A = +25 ± 3 °C, 5.6 V ≤ V_{Ay}, (ORx41A-xxx) ≤ 18 V, 5.6 V ≤ V_{Ay}, (ORx41B-xxx) ≤ 36 V, all LEDs enabled, unless otherwise specified.

Symbol	Parameter	Min.	Typ.	Max.	Units	Conditions	Test Setup Figure
I _{F,MAX}	Maximum Forward Continuous Current (per rectifier)			100	A	Devices ORM41x-100, -40 °C ≤ T _A ≤ +85 °C	
				150	A	Devices ORM41x-150, -40 °C ≤ T _A ≤ +85 °C	
				200	A	Devices ORM41x-200, -40 °C ≤ T _A ≤ +85 °C	
				250	A	Devices ORM41x-250, -40 °C ≤ T _A ≤ +85 °C	
				300	A	Devices ORM41x-300, -40 °C ≤ T _A ≤ +85 °C	
				400	A	Devices ORL41x-400, -40 °C ≤ T _A ≤ +85 °C	
				500	A	Devices ORL41x-500, -40 °C ≤ T _A ≤ +85 °C	
		600	A	Devices ORL41x-600, -40 °C ≤ T _A ≤ +85 °C			
I _{SURGE,MAX}	Maximum Surge Current (per rectifier)			5 x I _{F,MAX}	A	Pulse width = 2 s, -40 °C ≤ T _A ≤ +85 °C	
V _F	Forward Voltage Drop ⁽⁸⁾		30		mV	ORM41A-100, I _F = I _{F,MAX}	1
			42	45	mV	ORM41A-100, I _F = I _{F,MAX} , T _A = +85 °C	
			34		mV	ORM41A-150, I _F = I _{F,MAX}	
			46	49	mV	ORM41A-150, I _F = I _{F,MAX} , T _A = +85 °C	
			34		mV	ORM41A-200, I _F = I _{F,MAX}	
			45	48	mV	ORM41A-200, I _F = I _{F,MAX} , T _A = +85 °C	
			36		mV	ORM41A-250, I _F = I _{F,MAX}	
			48	51	mV	ORM41A-250, I _F = I _{F,MAX} , T _A = +85 °C	
			41		mV	ORM41A-300, I _F = I _{F,MAX}	
			53	56	mV	ORM41A-300, I _F = I _{F,MAX} , T _A = +85 °C	
			39		mV	ORL41A-400, I _F = I _{F,MAX}	
			51	56	mV	ORL41A-400, I _F = I _{F,MAX} , T _A = +85 °C	
			44		mV	ORL41A-500, I _F = I _{F,MAX}	
			57	63	mV	ORL41A-500, I _F = I _{F,MAX} , T _A = +85 °C	
			51		mV	ORL41A-600, I _F = I _{F,MAX}	
			66	73	mV	ORL41A-600, I _F = I _{F,MAX} , T _A = +85 °C	
			33		mV	ORM41B-100, I _F = I _{F,MAX}	
			48	51	mV	ORM41B-100, I _F = I _{F,MAX} , T _A = +85 °C	
			31		mV	ORM41B-150, I _F = I _{F,MAX}	
			45	48	mV	ORM41B-150, I _F = I _{F,MAX} , T _A = +85 °C	
			38		mV	ORM41B-200, I _F = I _{F,MAX}	
			55	58	mV	ORM41B-200, I _F = I _{F,MAX} , T _A = +85 °C	
			45		mV	ORM41B-250, I _F = I _{F,MAX}	
			65	68	mV	ORM41B-250, I _F = I _{F,MAX} , T _A = +85 °C	
			49		mV	ORM41B-300, I _F = I _{F,MAX}	
			72	76	mV	ORM41B-300, I _F = I _{F,MAX} , T _A = +85 °C	
			44		mV	ORL41B-400, I _F = I _{F,MAX}	
	62	68	mV	ORL41B-400, I _F = I _{F,MAX} , T _A = +85 °C			
	52		mV	ORL41B-500, I _F = I _{F,MAX}			
	74	81	mV	ORL41B-500, I _F = I _{F,MAX} , T _A = +85 °C			
	59		mV	ORL41B-600, I _F = I _{F,MAX}			
	83	91	mV	ORL41B-600, I _F = I _{F,MAX} , T _A = +85 °C			

Continued on next page...

ELECTRICAL SPECIFICATIONS (continued)

All devices ("x" = don't care), all amperages DC, all voltages DC and referenced to ground, "I_F" = rectifier forward current, "y" = 1(2) for anode 1(2) terminal, respectively, T_A = +25 ± 3 °C, 5.6 V ≤ V_{Ay} (ORx41A-xxx) ≤ 18 V, 5.6 V ≤ V_{Ay} (ORx41B-xxx) ≤ 36 V, all LEDs enabled, unless otherwise specified.

Symbol	Parameter	Min.	Typ.	Max.	Units	Conditions	Test Setup Figure
I _{over,trip}	Forward Over-current Indicator Trip		1.2 x I _{F,MAX}		A	-40 °C ≤ T _A ≤ +85 °C	1
I _{over,reset}	Forward Over-current Indicator Reset		I _{over,trip} - 10		A	-40 °C ≤ T _A ≤ +85 °C	1
I _s	Operating Current ⁽⁹⁾		0.7		mA	V _K = 5.5 V, Anodes floating, Combine not active, 1 minute after power application	2
			0.8		mA	V _K = 12.0 V, Anodes floating, Combine not active, 1 minute after power application	
			0.9		mA	V _K = 18.0 V, Anodes floating, Combine not active, 1 minute after power application	
			1.0		mA	Devices ORx41B-xxx, V _K = 24.0 V, Anodes floating, Combine not active, 1 minute after power application	
			1.3		mA	Devices ORx41B-xxx, V _K = 36.0 V, Anodes floating, Combine not active, 1 minute after power application	
			44		mA	V _{Ay} = 5.5 V, Cathode and other anode floating, Combine not active	3
			45		mA	V _{Ay} = 12.0 V, Cathode and other anode floating, Combine not active	
			47		mA	V _{Ay} = 18.0 V, Cathode and other anode floating, Combine not active	
			48		mA	Devices ORx41B-xxx, V _{Ay} = 24.0 V, Cathode and other anode floating, Combine not active	
			51		mA	Devices ORx41B-xxx, V _{Ay} = 36.0 V, Cathode and other anode floating, Combine not active	
			57		mA	V _{Ay} = 12.0 V, Cathode and other anode floating, Combine active (COMBINE+ and COMBINE- shorted)	
			64		mA	Devices ORx41B-xxx, V _{Ay} = 24.0 V, Cathode and other anode floating, Combine active (COMBINE+ and COMBINE- shorted)	

Continued on next page...

All devices ("x" = don't care), all amperages DC, all voltages DC and referenced to ground, "I_F" = rectifier forward current, "y" = 1(2) for anode 1(2) terminal, respectively, T_A = +25 ± 3 °C, 5.6 V ≤ V_{Ay}, (ORx41A-xxx) ≤ 18 V, 5.6 V ≤ V_{Ay}, (ORx41B-xxx) ≤ 36 V, all LEDs enabled, unless otherwise specified.

Symbol	Parameter	Min.	Typ.	Max.	Units	Conditions	Test Setup Figure
I _R	Reverse Leakage Current (per rectifier)			10	μA	V _K = 5.5 V, V _{Ay} = 0 V, Other anode floating	4
				20	μA	V _K = 12.0 V, V _{Ay} = 0 V, Other anode floating	
				20	μA	Devices ORM41A-100, ORM41A-150, and ORx41B-xxx, V _K = 18.0 V, V _{Ay} = 0 V, Other anode floating	
				65	μA	Devices ORM41A-200, ORM41A-250, and ORM41A-300, V _K = 18.0 V, V _{Ay} = 0 V, Other anode floating	
				45	μA	Devices ORx41B-xxx, V _K = 24.0 V, V _{Ay} = 0 V, Other anode floating	
				20	μA	Devices ORM41B-100 and ORM41B-150, V _K = 36.0 V, V _{Ay} = 0 V, Other anode floating	
				350	μA	Devices ORM41B-200, ORM41B-250, and ORM41B-300 V _K = 36.0 V, V _{Ay} = 0 V, Other anode floating	
				800	μA	Device ORL41B-400, V _K = 36.0 V, V _{Ay} = 0 V, Other anode floating	
				20	μA	Device ORL41B-500, V _K = 36.0 V, V _{Ay} = 0 V, Other anode floating	
				5000	μA	Device ORL41B-600, V _K = 36.0 V, V _{Ay} = 0 V, Other anode floating	
I _{COMBINE}	Combine Trigger Current		33		μA	COMBINE+ and COMBINE- shorted together	5
V _{COMBINE+}	COMBINE+ Floating Voltage		3.3		V		
V _{COMB,ON}	COMBINE+ Trigger On Voltage		V _{COMB,OFF} - 0.02		V		
V _{COMB,OFF}	COMBINE+ Trigger Off Voltage		2		V		
t _{RR}	Rectifier Reverse Recovery Time ⁽¹⁰⁾			1.3	ms	Devices ORx41A-xxx, I _F = 120 mA	6
				1.5	ms	Devices ORx41B-xxx, I _F = 120 mA	
t _{FET,START}	MOSFET Start-up Time ⁽¹¹⁾		130		ms	V _{Ay} = 0 to 12 V, Cathode and other anode floating	7
				5	ms	V _K = 14 V to floating, V _{Ay} = 12 V, Other anode floating	8

NOTES

- Stresses beyond those listed under absolute maximum ratings may cause permanent damage to the device. Exposure to any absolute maximum rating condition for extended periods may affect device reliability and lifetime.
- Transient-protected to 40 V. Additional external protection may be required in some applications.
- Transient-protected to 60 V. Additional external protection may be required in some applications.
- Transient-protected to -40 V. Additional external protection may be required in some applications.
- Transient-protected to -60 V. Additional external protection may be required in some applications.
- Limits may vary depending upon V_{Ka} and V_{Kk} voltages. For example, on ORx41A-xxx (ORx41B-xxx) devices, if V_{A1} = -12 V (-24 V), then V_{A2,max} = 9 V (15 V), respectively.

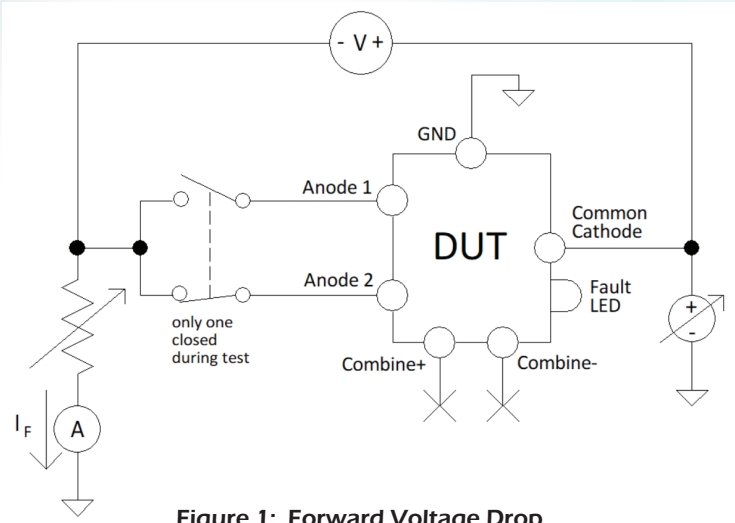

Figure 1: Forward Voltage Drop

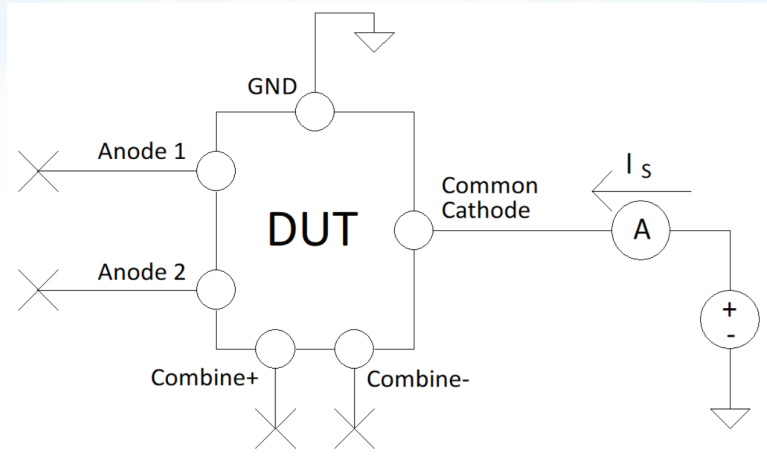

Figure 2: Operating Current ($V_K > V_{A1}$ and V_{A2})

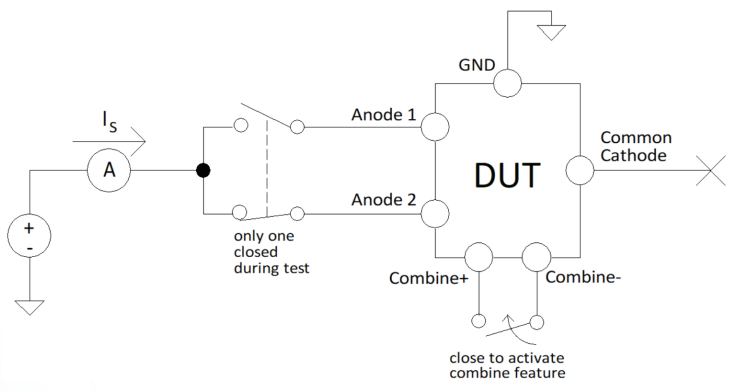

Figure 3: Operating Current ($V_{Ay} > V_K$)

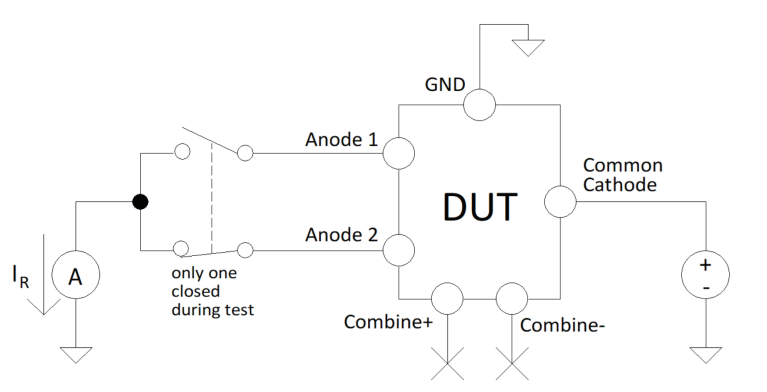

Figure 4: Reverse Leakage Current

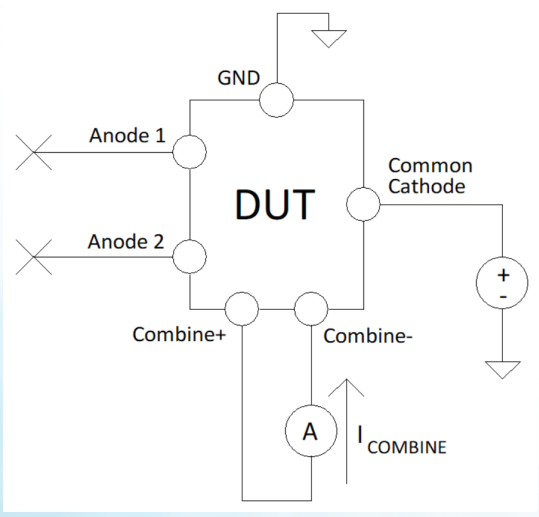

Figure 5: Combine Trigger Current

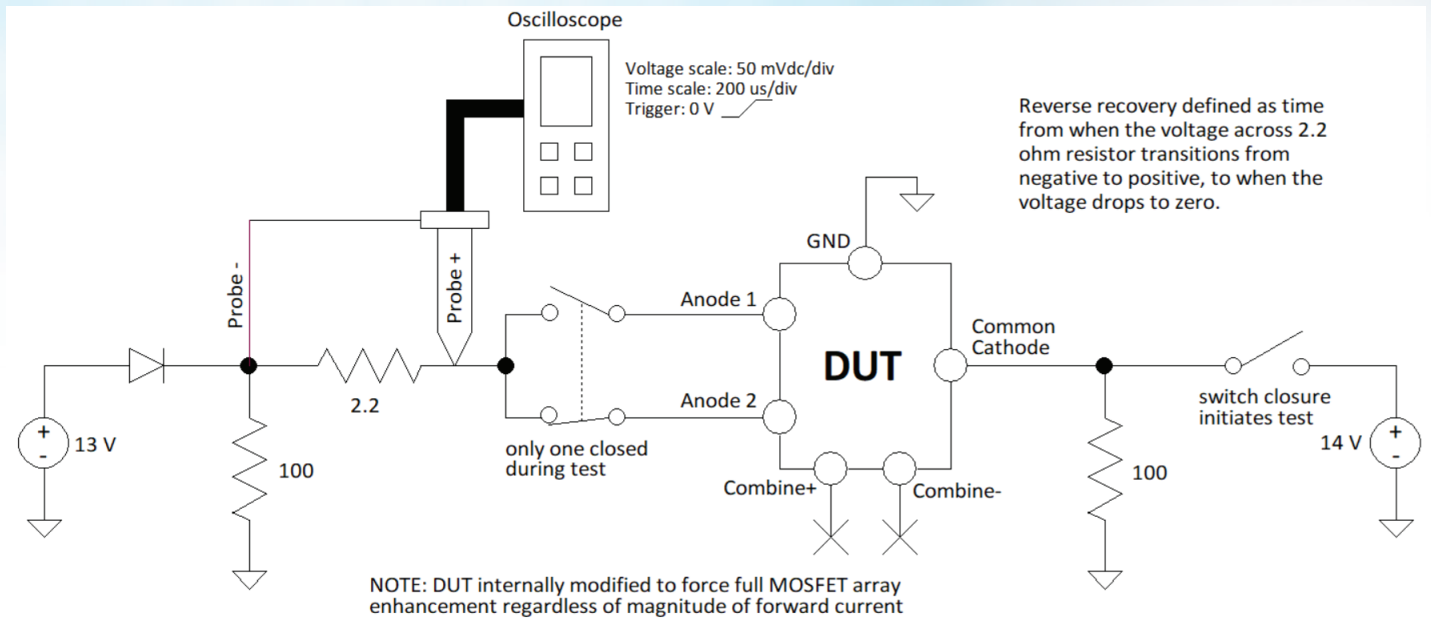

Figure 6: Reverse Recovery Time

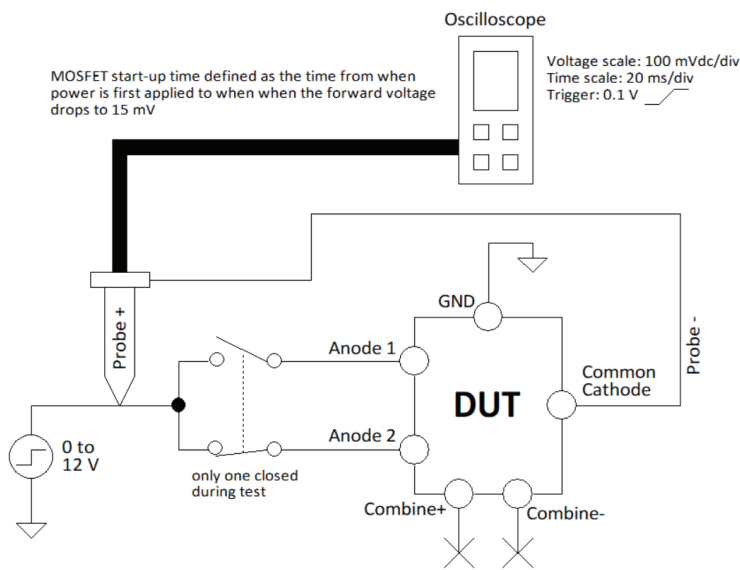

Figure 7: MOSFET Start-up Time (Unpowered)

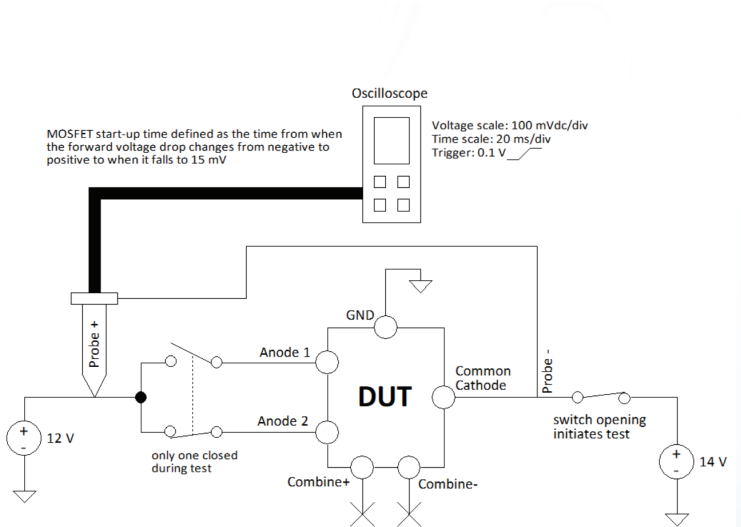
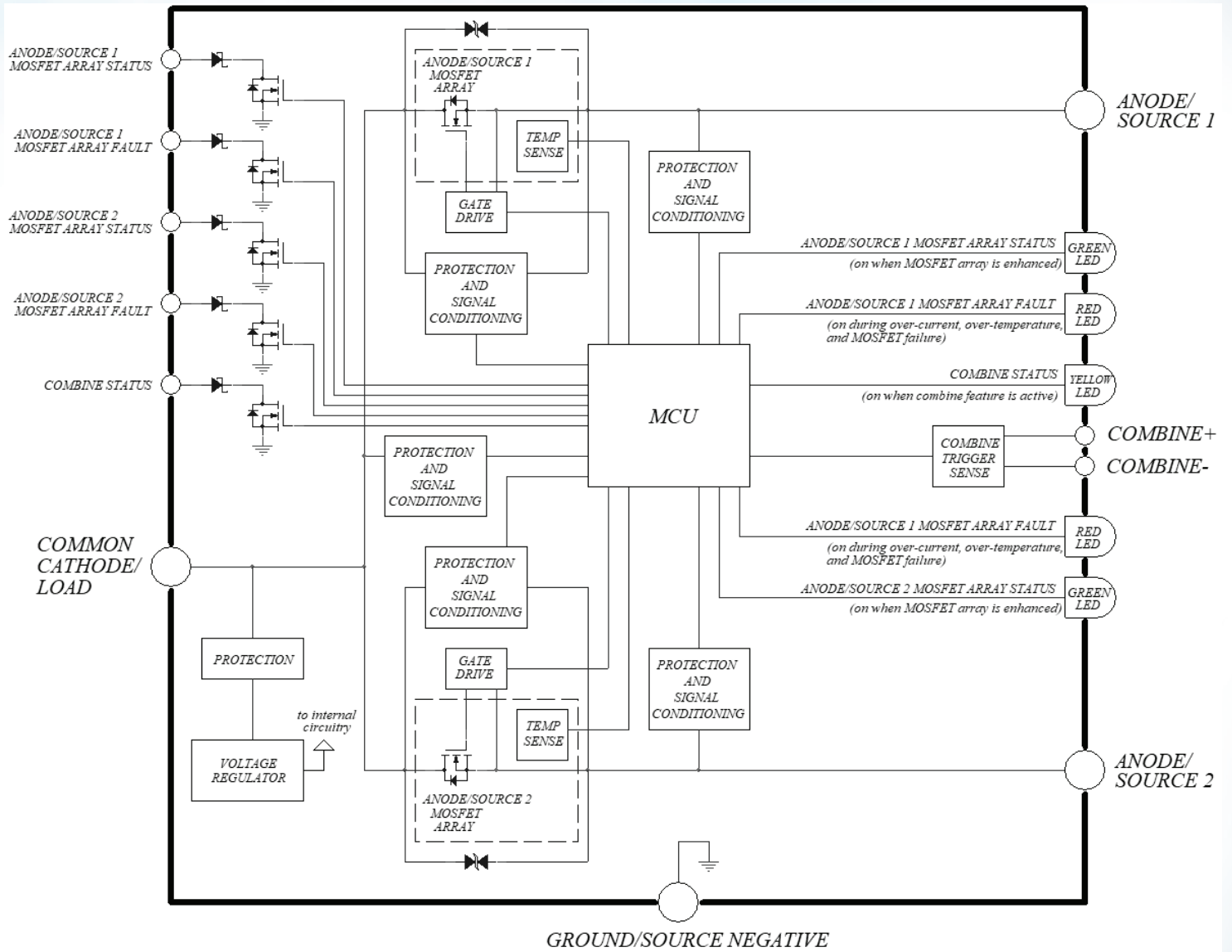

Figure 8: MOSFET Start-up Time (Powered)

FUNCTIONAL BLOCK DIAGRAM



MECHANICAL

MEDIUM PACKAGE

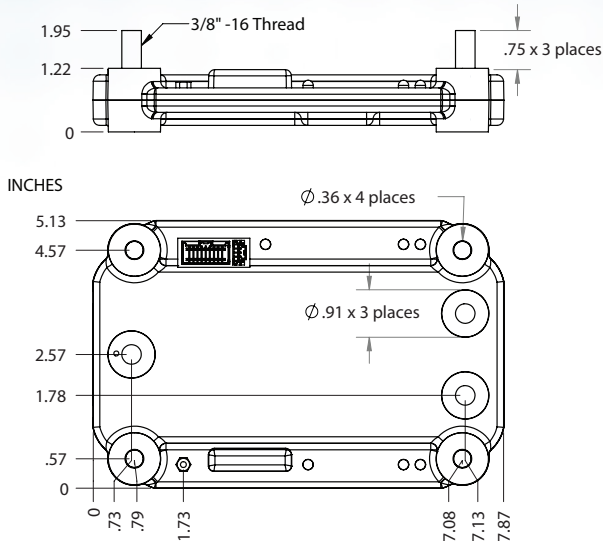

LARGE PACKAGE

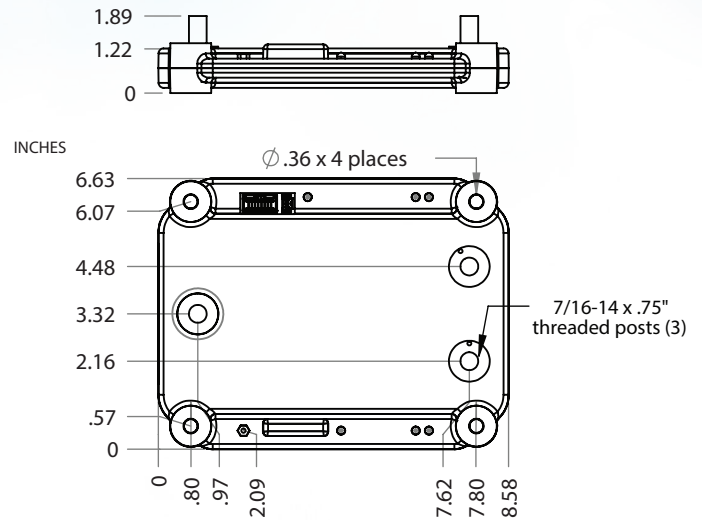

PACKAGE CHARACTERISTICS:

- Injection molded high temperature polycarbonate shell
- Dow Corning Sylgard - aerospace electronics grade
- Six integrated LED's for visual status and diagnostics
- Four integrated reinforced mounting points
- Machined brass connection posts with provided brass washers, and nylon insert nuts. Mounting torque not to exceed 15 newton-meters
- 6-32 brass ground post with provided ring terminal
- Molex top-mounted control harness (if needed) and expansion post for remote monitoring display
- Vinyl post insulators
- Two enclosure size options, current depending
- Typical weight post-encapsulation including provided hardware:

Medium Package	23.5 ounces (+ / - 10%)
Large Package	58 ounces (+ / - 10%)

The POWER-GATE Non-Programmable OR'ing is designed to selectively OR one of two sources to a load. The device will automatically conduct current from the source with higher voltage (relative to device ground) to the load. When the primary source drops below the secondary source, the device will "flip," and current from the secondary will drive the load. The orientation of the internal MOSFET arrays insures there will be no disruption in power driving the load, even when transitioning from one source to another.

If source voltage levels are sufficiently close enough, dynamic voltage sag/rise of one source in response to the opposing source sag/rise can cause oscillation or rapid-switching between the sources. In this case, the "Programmable" OR'ing should be considered. Contact engineering for assistance.

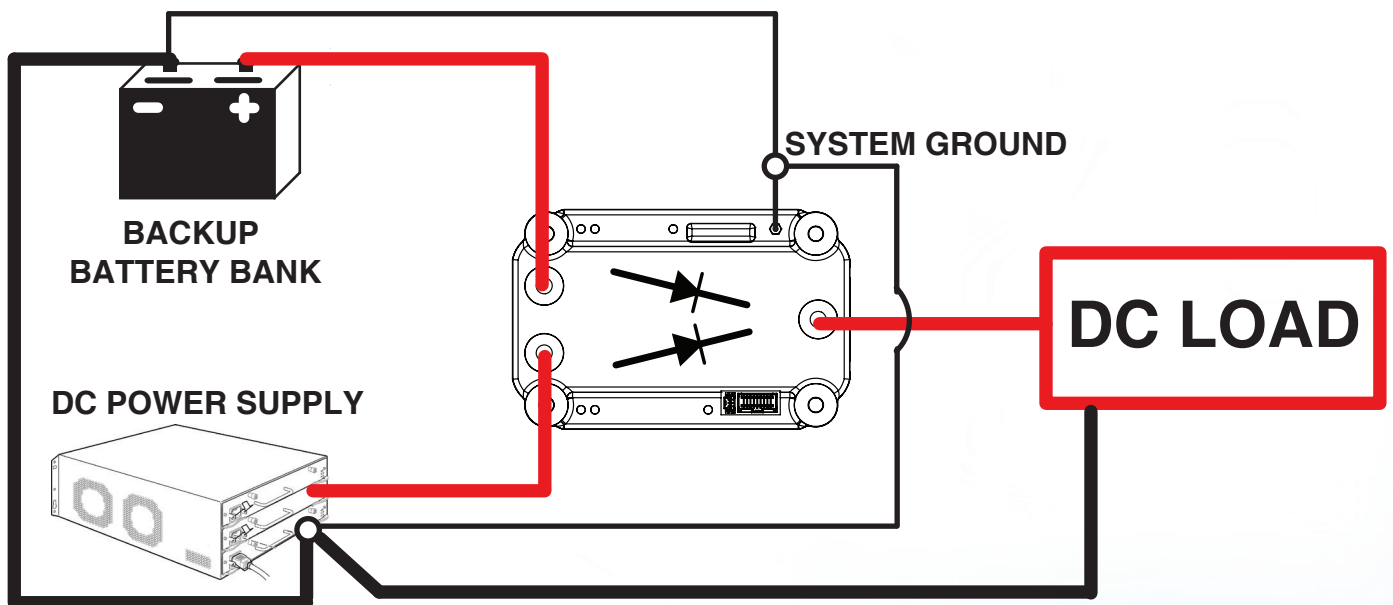

Revision History

Rev	Date	Description	Page Number(s)
0	11/7/2023	Original Release	-

 DANGER / PELIGRO / DANGER /GEFAHR / PERICOLO / PERIGO					
<p>HAZARD OF ELECTRIC SHOCK, EXPLOSION, OR ARC FLASH.</p> <ul style="list-style-type: none"> Disconnect all power before installing or working with this equipment. Verify all connections and replace all covers before turning on power. <p>Failure to follow these instructions will result in death or serious injury.</p>	<p>RIESGO DE DESCARGA ELECTRICA O EXPLOSION.</p> <ul style="list-style-type: none"> Desconectar todos los suministros de energia a este equipo antes de trabajar con este equipo. Verificar todas las conexiones y colocar todas las tapas antes de energizar el equipo. <p>EI incumplimiento de estas instrucciones puede provocar la muerte o lesiones serias.</p>	<p>RISQUE DE DESCARGE ELECTRIQUE OU EXPLOSION</p> <ul style="list-style-type: none"> Eteindre toutes les sources d'énergie de cet appareil avant de travailler dessus de cet appareil Vérifier tous connections, et remettre tous couverts en olace avant de mettre sous <p>De non-suivi de ces instructions provoquera la mort ou des lésions sérieuses.</p>	<p>GEFAHR EINES ELEKTRISCHE N SCHLAGES ODER EINER EXPLOSION.</p> <ul style="list-style-type: none"> Stellen Sie jeglichen Strom ab, der dieses Gerät versorgt, bevor Sie an dem Gerät Arbeiten durchführen Vor der Inbetriebnahme alle Anschlüsse überprüfen und alle Gehäuseteile montieren. <p>Unterlassung dieser Anweisungen können zum Tode oder zu schweren Verletzungen führen.</p>	<p>RISCHIO DI SCOSSA ELETTRICA O DELL'ESPLOSIONE.</p> <ul style="list-style-type: none"> Spenga tutta l'alimentazione e che fornisce questa apparecchiatura prima del lavorare a questa apparecchiatura Verificare tutti i collegamenti e sostituire tutte le coperture prima della rotazione sull'alimentazione <p>L'omissione di seguire queste istruzioni provocherà la morte o di lesioni serie</p>	<p>RISCO DE DESCARGA ELÉTRICA OU EXPLOÇÃO</p> <ul style="list-style-type: none"> Desconectar o equipamento de toda a energia antes de instalar ou trabalhar com este equipamento Verificar todas as conexões e recolocar todas as tampas antes de religar o equipamento <p>O não cumprimento destas instruções pode levar à morte ou lesões sérias.</p>