

# POWER-GATE™ Solid-State Devices

## Non-Programmable OR-ing



Made in U.S.A

**up to 600 Amps**  
**12 and 24 Volts**



**A solid state Non-Programmable OR-ing module will selectively OR one of two sources to a load, with no loss of power to the load during switching. POWER-GATE devices don't arc, require minimal trigger current, and are highly reliable in dust and vibration laden environments.**

POWER-GATE solid state Non-Programmable OR-ing modules are designed to automatically OR one of two sources to a load. The device will automatically conduct current from the source with the higher voltage (relative to device ground) to the load. When the primary source voltage drops below the secondary source voltage, the device will "flip," and current from the secondary source will drive the load. The orientation of the MOSFET arrays insures no disruption in power driving the load (no dead-time), even when transitioning from one source to another.

If source voltage levels are sufficiently close enough, dynamic voltage sag/rise of one source in response to the opposing source voltage sag/rise can cause oscillation or rapid-switching between sources, in which case the Programmable OR-ing should be considered. Devices are strictly DC, and have no mechanical contacts or moving parts which means no arcing or degradation in performance over time. An integrated microcontroller provides primary functionality to achieve the following:

- OR's two sources to a single load
- Industry-leading ultra-low on-state resistance
- No heat-sinks or airflow required
- No de-rating required over full temperature range
- Low voltage, high current capability
- Dielectric gel encapsulation
- Fault status and troubleshooting feedback
- Internationally patented dual arrayed MOSFET technology

### APPLICATIONS:

A dual arrayed MOSFET configuration used to isolate redundant power sources so a failure of one source doesn't bring down the whole system. A system may have a critical piece of equipment powered by a DC power supply OR a backup battery bank. If the DC power supply should ever fail, the backup battery bank will instantly become the source of power for the critical piece of equipment; whichever source is more positive will be "OR'ed" to the load.

POWER-GATE OR'ing diodes provide high performance and reliable switching without the conductive losses and leakage typical to Schottky rectifiers.

Common uses include military, aeronautic, automotive, marine, industrial machinery, photovoltaic, and fleet utility.

### FEATURES and BENEFITS:

- Low voltage, high current capability
- Internationally patented arrayed MOSFET technology
- Two package options for currents up to 600 amps
- 99.9% efficiency at max. current
- Fully Encapsulated solid state design
- Light weight
- Dramatically smaller than conventional devices
- Market-leading, ultra-low on-state resistance
- Recommended by top battery manufacturers
- No heat sinks or airflow required
- Quik-turn capability
- User replaceable fuse
- LED indicators for visual feedback
- Overcurrent indication
- Overtemperature indication
- Voltage transient self-protection
- Fully autonomous operation

## MECHANICAL SPECIFICATIONS:

### MEDIUM PACKAGE

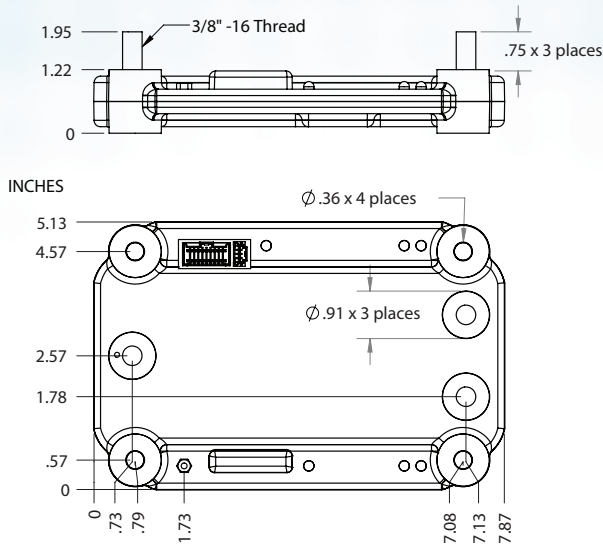

### LARGE PACKAGE

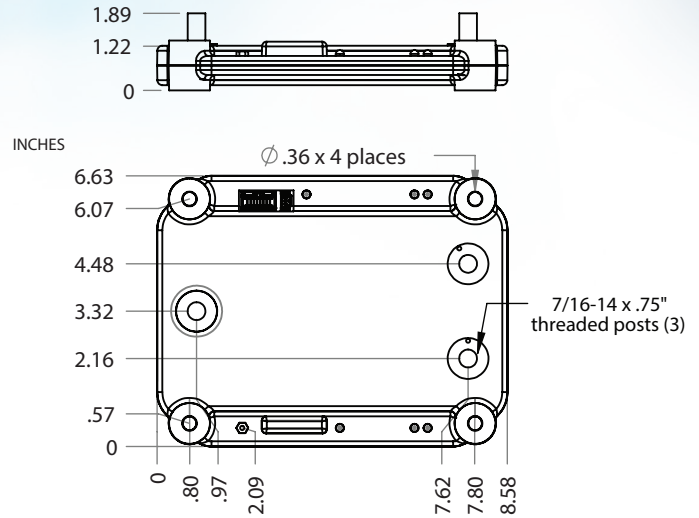

### PACKAGE CHARACTERISTICS:

- Injection molded high temperature polycarbonate shell
- Dow Corning Sylgard - aerospace electronics grade
- Six integrated LED's for visual status and diagnostics
- Four integrated reinforced mounting points
- Machined brass connection posts
- 6-32 brass ground post with provided ring terminal
- Optional Molex monitoring harness
- Vinyl post insulators
- Two enclosure size options, current depending

### Quick Specs:

Supply Voltage	4.8 to 18 VDC (12 volt device) 4.8 to 36 VDC (24 volt device)
Ambient Temperature	-40 to +85 °C
Maximum Continuous Load Current	100 to 600 amps DC
Input-to-Output Voltage Drop	35 to 55 mVDC Typical
Reverse Leakage Current	30 µADC (12 volt device) 75 µADC (24 volt device)
Operating Current	22.9 mADC (12 volt device, trigger at 12 VDC) 23.7 mADC (24 volt device, trigger at 24 VDC)
Quiescent Current	0.84 mADC (12 volt device) 1.01 mADC (24 volt device)
Internal Overtemp Shutdown	135 °C

### OR Series Functional Block Diagram:

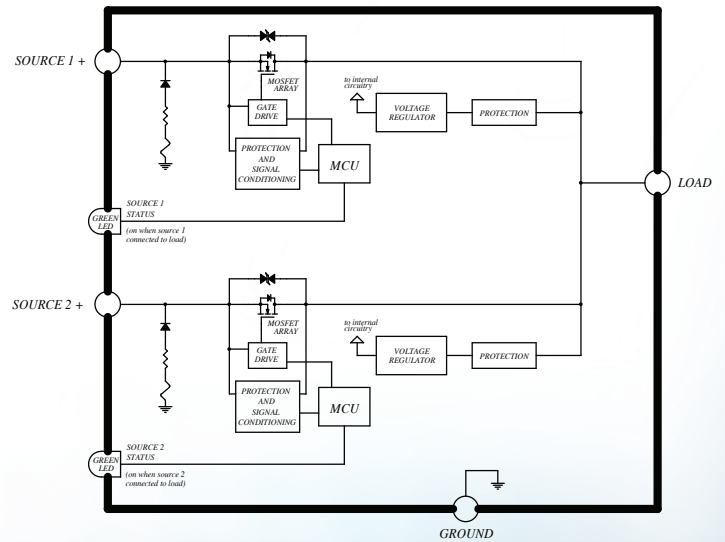

### NOTES:

For complete specifications, please see device data sheet.

The **POWER-GATE Non-Programmable OR'ing** is designed to selectively OR one of two sources to a load. The device will automatically conduct current from the source with higher voltage (relative to device ground) to the load. When the primary source drops below the secondary source, the device will "flip," and current from the secondary will drive the load. The orientation of the internal MOSFET arrays insures there will be no disruption in power driving the load, even when transitioning from one source to another.

If source voltage levels are sufficiently close enough, dynamic voltage sag/rise of one source in response to the opposing source sag/rise can cause oscillation or rapid-switching between the sources. In this case, the "Programmable" OR'ing should be considered. Contact engineering for assistance.

