

POWER-GATE INSTALLATION INSTRUCTIONS

SR-Series Single Rectifier Isolator / Ideal Diode GEN 4.1 Small Enclosure, v4

Congratulations on your POWER-GATE purchase! POWER-GATE is designed to provide years of trouble-free operation. Please read the instructions in their entirety prior to undertaking installation. Like any work performed around batteries, electrical circuits, vehicles, and moving parts, exercise caution to insure safe installation and use. If you are not familiar with batteries, electrical circuits, or basic auto/marine-electrical architecture, seek the assistance of a professional installer. Failure to install POWER-GATE correctly may cause poor performance, premature product failure, personal injury, or possibly damage to the vehicle or vehicle accessories.



The manufacturer is not responsible for damage incurred due to improper installation.

PRE-INSTALLATION

PACKING LIST:

- POWER-GATE Single Rectifier
- Control Harness, 1 meter length (optional)
- Nylon insert nuts, 5/16-18 (2)
- Brass washers, 5/16 hole size (2)
- Ground ring terminal w/ 6-32 screw
- Installation and Data sheets

WHAT YOU WILL NEED:

- Copper lugs for cable terminations
- Protection fuses or breakers as needed
- Drill and appropriate mounting hardware
- Digital multi-meter
- 5/16 torque wrench
- 16 AWG black wire for ground extension
- Wire stripper
- Lug crimper
- Soldering torch, solder, and flux



MOUNTING: Mount module on a flat surface. Failure to do so may cause "twisting" of the internal assembly and lead to mechanical breakdown.

CONNECTING LUGS TO CABLES

POWER-GATE™ is engineered to transfer electricity at peak performance levels approaching 99.9%. Unfortunately, most installers often overlook electrical joints between cables, lugs, and battery terminals. POWER-GATE™ is one part of a complete electrical system; cables and connection points require just as much attention as the connections to POWER-GATE™ itself.

- Cables should be flexible, free of oxidation, and coated with neoprene or some sort of insulation.
- Cable cross-section should be appropriately sized for the distance and peak current being transferred.
- SR100 thru SR300, use at least #4 cable and preferably larger for better efficiency.
- SR400 applications, use at least 2/0 cable.
- SR500 applications, use at least 3/0 cable.
- SR600 applications, use at least 4/0 cable.
- Don't guess the correct cable size.
- Lugs made of copper, silver-plated copper, or tin-plated copper are good conductors.

Creating a good joint between cables and connectors ensures efficient transfer of electricity. Lugs should be soldered to cables or hydraulically crimped with industry standard crimping equipment. To properly connect cable to lug:

1. Strip cable's insulation material exposing copper strands of cable.
2. "Tin" copper strands by first covering with solder flux. Heat copper strands with torch until solder melts into copper strands. The goal is to pre-saturate or solder-pot the copper strands with solder.
3. Insert solder slugs into lug barrel followed by tinned cable.
4. Use torch to heat lug and cable. When the solder slugs melt, molten solder from tinned cable and solder slugs will combine while inserting cable into lug.
5. Remove heat and allow lug and cable to cool.
6. Once cool, use heat shrink wrap or electrical tape to create moisture barrier between cable insulation and lug.

This method should produce a sound electrical joint. Later, use a digital multi-meter to insure connection is efficient at elevated current.

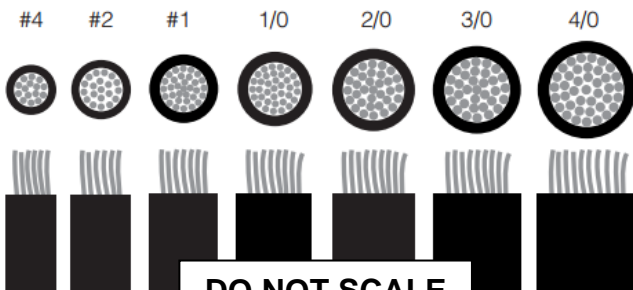

CONNECTING CABLES TO POWER-GATE™

POWER-GATE™ does not use cooling fins commonly present on high-current switches. It is critical that cable connections to connection posts provide optimum surface area contact for two reasons: proper cooling and proper current conductivity.



Nut

Washer

Lug

Brass Flange

CRITICAL TORQUE VALUE

It is critical that a calibrated torque wrench is utilized when attaching nylon insert nuts to brass posts. Improper under-torque may cause unnecessary electrical resistance while improper over-torque may spin the brass assembly internally or possibly break off the brass post.

Use 75 inch-pounds on the 2 primary connection posts.

INSTALLATION INSTRUCTIONS FOR DUAL BATTERIES

Step 1 With engine off, remove all wires and cables from negative terminal of all batteries.

Step 2 Slip existing cable/wire off primary alternator post. Insulate with electrical tape and secure from rotating parts.

Step 3 Select desired location for POWER-GATE Module; keep the following points in mind:

- Distance to the alternator and batteries
- Easy access to POWER-GATE
- Footprint doesn't conflict with other wires, cables, reservoirs, rotating parts etc...
- Adequate distance from high-heat sources like exhaust manifold

Step 4 **Mount device on a flat surface** using the four mounting holes being careful not to exceed 5 foot-pounds of torque and appropriate hardware for your given installation. **Uneven twisting or torsional stress may cause damage to the internal electronics assembly.**

Step 5 Connect POWER-GATE ground wire to best electrical ground (ex. Ideally either battery negative terminal) **before proceeding to Step 5.**

Step 6 If present, connect Violet wire to switched system power (12 or 24 volts).

Step 7 Connect cable(s) to POWER-GATE anode as shown in diagram. **FUSE** and insulate appropriately. Torque nylon insert nut to 75 inch-pounds +5/-0 (8.5 newton-meters). Note that a fresh piece of cable should bond the alternator output post to the anode, and a fresh piece of cable should bond the aux. battery positive to the anode post.

Step 8 Connect cable(s) to POWER-GATE cathode as shown in diagram and insulate appropriately. Torque nylon insert nut to 75 inch-pounds +5/-0 (8.5 newton-meters)

Step 9 Run a ground cable from main battery ground post to aux. battery ground post (if possible).

Step 10 **BEFORE RECONNECTING BATTERIES**, verify that your installation matches the SR-Series diagram.

Step 11 Re-connect ground cables to the negative posts on batteries. The GREEN led(s) should instantly illuminate **if** aux. battery is of equal or higher voltage than the cathode battery. If not, **STOP**, check your work, and call for technical support.

Step 12 Restore ground connections on both batteries and proceed

POST INSTALLATION CHECKOUT

Assumptions:

- Both AUXILIARY and MAIN batteries are connected and have a normal static voltage of 12 to 13 volts.
- Cables and connections are pristine and electrically sound, not poor, corroded, or high resistance.
- Alternator is in good working order and with the vehicle running, the output voltage is between 13 to 14.9 VDC (26 to 29.8 VDC for 24 volt vehicles).
- With the vehicle running, both green LEDS should be illuminated, provided the alternator is creating output. When the vehicle is turned-off, the green LEDS should extinguish.

Using your digital multi-meter, perform the following checks:

1. Read the DC voltage from the anode to ground. This should reflect the DC voltage of the alternator.
2. Read the DC voltage from the cathode "A" to ground. This should reflect the DC voltage of the MAIN battery.
3. Read the DC voltage from the cathode "B" to ground. This should reflect the DC voltage of the AUXILIARY battery.
4. With one probe on the anode and one probe on one cathode, the multi-meter will reflect the difference between these two points and should reflect less than 0.05 volts. If greater, shut the vehicle down and call support. There should never be more than 0.05 volts drop between the anode and cathode blades at **maximum rated current**.

INSTALLATION INSTRUCTIONS IDEAL DIODE

Module must be connected to a common system ground (battery or power supply negative) in order to function correctly.

Like a conventional diode, when anode voltage is more positive than cathode voltage, the MOSFET 'diode' will conduct. If cathode voltage becomes more positive than anode voltage, the device will go into 'diode' mode and cease to conduct current from cathode-to-anode.

Ideal Diode sample diagram

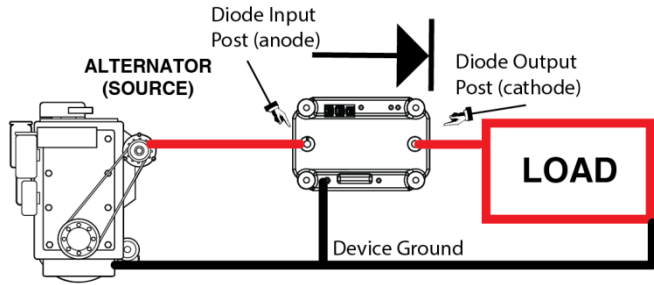

Red LED will illuminate under these conditions:

- 1) Blinking RED LED indicates over-current. Amount of current exceeds device rating. Reduce current.
- 2) Steady-on RED LED indicates sensed fault condition. Remove device from service and contact manufacturer.

Dual Batteries sample diagram

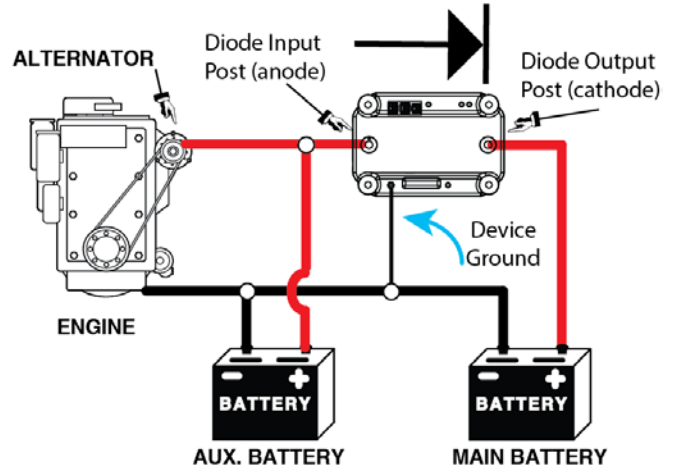

EXTERNAL LED HARNESS 6055 Rev C (Available upon request)

HOW POWER-GATE™ FUNCTIONS

The POWER-GATE™ Module is an extremely efficient ideal diode, or one-way electrical valve. It provides electrical conduction from anode to cathode more efficiently than the cables attached to it.

The **GREEN** LED indicates anode voltage is the same, or more positive than the cathode voltage therefore the MOSFET array is enhanced allowing current to flow in a uni-directional fashion from anode to cathode.

If the **GREEN** LED is **not** illuminated, it means the following:

- the voltage at the anode is less than the voltage at the cathode indicating rectifier is de-energized and blocking current flow from cathode-to-anode
- Under-voltage (less than 8 volts)

The **RED** LED will illuminate in the case of over-current or fault.

The **YELLOW** LED will illuminate when the excitation feature is triggered and active.

POWER-GATE™ is encapsulated to provide rigidity, and protection from chemicals, dirt, and moisture.

PIN	DESCRIPTION	LED COLOR
1	Array Status	Green
2	Empty	
3	Alternator Excite / Combine Active	Violet
4	Empty	
5	Empty	
6	Empty	
7	Empty	
8	Empty	
9	Array Fault	Red
10-18	Empty	

Connector housing Molex 51353-1800
Terminals Molex 56134-9000
Control harness, three meters, 24 AWG wires, -UL style 1007/1569
No strip on loose-wire end

All lines are active-low and should be voltage / current-limited to 60V / 50mA, respectively

COMBINE BATTERY FEATURE (optional)

Joining the Brown and Blue wires together will enable the battery combine feature, if programmed into the device. When enabled, the **YELLOW** LED will illuminate, and current can flow from bi-directionally between anode and cathode. The direction of current flow will depend on the state of charge of the batteries in the system. To disable the combine feature, open the connection between the Brown and Blue wires. A switch can be fitted between the Brown and Blue wires for convenience. The switch need only handle micro-amperes so any single pole, single throw switch, or an on-off-(on momentary) DPDT switch will do. **If left in the enable mode, battery isolation will NOT take place.**

The device requires a minimum of 5.5VDC from one of the batteries to operate properly and damage to the device may occur if the combine feature is enabled when the batteries are in an unhealthy state.

CONTROL HARNESS 6057 Rev B (Available upon request)

PIN	DESCRIPTION	LED COLOR
1	Starter	Orange
2	Main Trigger +	not used DR/SR
3	Ignition	Violet
4	Empty	
5	Econo Trigger	Green
6	Empty	
7	Combine Trigger -	Brown
8	Combine Trigger +	Blue

Connector housing Molex 051353-0800
Terminals Molex 56134-9000
Control harness, two meters, 24 AWG wires, UL style 1007/1569
No strip on loose-wire end

Note to User: Depending on application, some wires shown may not be installed.

ALTERNATOR EXCITATION TRIGGER (optional)

DO NOT USE BOTH EXCITATION TRIGGER WIRES. USE ONE OR THE OTHER

Starter Trigger: Upon application on the starter line of a voltage greater than the turn-on threshold (~2 V) for at least 80 milliseconds, the device will wake up from its sleep mode and wait for a disappearance of the starter signal, indicating the starter has been released and, presumably, the cranking process has completed. The device will then wait four seconds before initiating the alternator excitation sequence. After the four seconds has elapsed, the MOSFET array connected to the main battery will turn on to connect the battery to the alternator, allowing its regulator to begin operation. The array will remain on for approximately half a second; during this time, the device will be looking for the moment when the alternator voltage rises above that of the main battery. If this occurs, the excitation sequence is ended and the device will transition into its standard ideal diode mode. If not, once the half second on-time has elapsed the main array will shut off. Approximately 3 seconds later, the device will try exciting the alternator once again (with a half-second on-time). This process will occur a maximum of five times; if the alternator fails to begin charging after the fifth time, the device will immediately go to sleep and wait for another positive-going starter signal.

Ignition Trigger: Upon application on the ignition line of a voltage greater than the turn-on threshold (~2 V), the device will first wait four seconds before initiating the alternator excitation sequence. This allows cranking to occur without a possible depleted auxiliary battery loading down the engine. After the four seconds has elapsed, the MOSFET array connected to the main battery will turn on to connect the battery to the alternator, allowing the regulator to begin operation. The array will remain on for approximately half a second; during this time, the device will be looking for the moment when the alternator voltage rises above that of the main battery. If this occurs, the excitation sequence is ended and the device will transition into its standard ideal diode mode. If not, once the half-second on-time has elapsed, the main array will shut off. Approximately 3 seconds later, the device will try exciting the alternator once again (with a half-second on-time). This process will occur a maximum of five times; if the alternator fails to begin charging after the fifth time, the device will immediately go to sleep and wait for another positive-going ignition signal. The user will note the Yellow LED will be on when the excitation sequence is active.

DEVICE FAILURE



Should POWER-GATE cease to function correctly for any reason, it is important to remove the device from the electrical circuit. Like any component in an electrical distribution circuit, if it is not functioning correctly, the POWER-GATE will dissipate heat as current passes through it. If ignored, heat related damage could result if a faulty device is not removed. Perfect Switch, LLC cannot be responsible in any way for ancillary damage to the vehicle and equipment installed in, on, or about the vehicle. Electronic components can cease to function at any time. It is the operator's responsibility to frequently assess the health of the electrical system to ensure a safe and reliable working environment.

POWER-GATE ONE-YEAR LIMITED WARRANTY

Perfect Switch, LLC, warrants the POWER-GATE against all defects in materials and workmanship for a period of one year from the date of the original purchase, subject to the following terms and conditions: This warranty does not apply if the serial number or housing of the product has been removed or if the product has been subjected to physical abuse, improper installation, water damage, corrosion due to sea salt, road salts, or deicing chemicals, transient voltage spikes, or modification.

To obtain warranty service, please contact the manufacturer for a Return Materials Authorization (RMA) number. The product must be returned, insured and shipping prepaid, to Perfect Switch, LLC at the address below, in its original packaging or a suitable equivalent, along with the purchaser's receipt and written description of the problem.

Perfect Switch, LLC's responsibility under this warranty is limited to repair or replacement of the product or refund of its purchase price, at the sole discretion of Perfect Switch, LLC. Perfect Switch, LLC, disclaims all other warranties, expressed or implied, including warranties of merchantability and fitness for any particular purposes whatsoever, and no other remedy shall be available including without limitation, incidental or consequential damages, loss of time, inconvenience, or commercial loss. In no event shall Perfect Switch, LLC's liability exceed the purchase price of the product in question.

Some states do not allow the exclusion or limitation of incidental or consequential damages of how long an implied warranty lasts, so the above limitations or exclusions may not apply to you.

This warranty gives you specific rights. You may have other legal rights which may vary from state to state. Perfect Switch, LLC, wants you to be satisfied with its products. Should you have any difficulties with the operation or performance of your POWER-GATE multi-battery accessory, please the manufacturer.

