

# POWER-GATE™ Solid-State Devices Dual Rectifier, Medium Package



Made in U.S.A



## DRM41 Specification Sheet Generation 4.1

### ABSOLUTE MAXIMUM RATINGS<sup>(1)</sup>

All devices ("x" = don't care) , all amperages DC, all voltages DC and referenced to device ground, unless otherwise specified.

Symbol	Parameter	Min.	Max.	Units
$V_{KA}$	Cathode-to-Anode Voltage, Model DRM41A-xxx	-	21 <sup>(3)</sup>	V
	Cathode-to-Anode Voltage, Model DRM41B-xxx	-	39 <sup>(4)</sup>	
$V_{KK}$	Cathode-to-Cathode Voltage, Model DRM41A-xxx	-21	21	V
	Cathode-to-Cathode Voltage, Model DRM41B-xxx	-39	39	
$V_A$	Anode Voltage, Model DRM41A-xxx	-21 <sup>(2)</sup>	21 <sup>(2,3)</sup>	V
	Anode Voltage, Model DRM41B-xxx	-39 <sup>(2)</sup>	39 <sup>(2,4)</sup>	
$V_K$	Cathode Voltage, Model DRM41A-xxx	-	21 <sup>(3)</sup>	V
	Cathode Voltage, Model DRM41B-xxx	-	39 <sup>(4)</sup>	
$I_{F, \text{gndfloat}}^{(5)}$	Forward Current (per rectifier, ground floating), DRM41x-100	-	10	A
	Forward Current (per rectifier, ground floating), DRM41x-150	-	15	
	Forward Current (per rectifier, ground floating), DRM41x-200	-	20	
	Forward Current (per rectifier, ground floating), DRM41x-250	-	25	
	Forward Current (per rectifier, ground floating), DRM41x-300	-	30	
$T_A$	Ambient Temperature	-45	+110	°C
$V_{IGN}$	Ignition Alternator Excitation Trigger Voltage	-39 <sup>(6)</sup>	39 <sup>(4)</sup>	V
$V_{STARTER}$	Starter Alternator Excitation Trigger Voltage	-39 <sup>(6)</sup>	39 <sup>(4)</sup>	
$I_{LED, \text{MAX}}$	Remote LED Maximum Current	-	50	mA
$V_{LED(OFF), \text{MAX}}$	Remote LED Maximum Voltage (LED Off)	-60	60	V

### RECOMMENDED OPERATING CONDITIONS

All devices ("x" = don't care) , all voltages DC and referenced to device ground, unless otherwise specified.

Symbol	Parameter	Min.	Max.	Units
$V_A$	Anode Voltage, Model DRM41A-xxx	5.6	18	V
	Anode Voltage, Model DRM41B-xxx	5.6	36	
$V_K$	Cathode Voltage (anode voltage at min), Model DRM41A-xxx	5.5	18	V
	Cathode Voltage (anode voltage at min), Model DRM41B-xxx	5.5	36	
$T_A$	Ambient Temperature	-40	+85	°C
$V_{IGN}$	Ignition Alternator Excitation Trigger Voltage	0	36	V
$V_{STARTER}$	Starter Alternator Excitation Trigger Voltage	0	36	

Perfect Switch, LLC  
(858) 720-1339  
www.perfectswitch.com

### ELECTRICAL SPECIFICATIONS

All devices ("x" = don't care), all amperages DC, all voltages DC and referenced to ground,  
 $T_A = +25 \pm 3 \text{ }^\circ\text{C}$ ,  $5.6 \text{ V} \leq V_A$  (DRM41A-xxx)  $\leq 18 \text{ V}$ ,  $5.6 \text{ V} \leq V_A$  (DRM41B-xxx)  $\leq 36 \text{ V}$ , all LEDs enabled, unless otherwise specified.

Symbol	Parameter	Min.	Typ.	Max.	Units	Conditions	Test Setup Figure
$I_{F,MAX}$	Maximum Forward Continuous Current (per rectifier)	-	-	100	A	Model DRM41x-100, $-40 \text{ }^\circ\text{C} \leq T_A \leq +85 \text{ }^\circ\text{C}$	-
		-	-	150		Model DRM41x-150, $-40 \text{ }^\circ\text{C} \leq T_A \leq +85 \text{ }^\circ\text{C}$	
		-	-	200		Model DRM41x-200, $-40 \text{ }^\circ\text{C} \leq T_A \leq +85 \text{ }^\circ\text{C}$	
		-	-	250		Model DRM41x-250, $-40 \text{ }^\circ\text{C} \leq T_A \leq +85 \text{ }^\circ\text{C}$	
		-	-	300		Model DRM41x-300, $-40 \text{ }^\circ\text{C} \leq T_A \leq +85 \text{ }^\circ\text{C}$	
$I_{SURGE,MAX}$	Maximum Forward Surge Current (per rectifier)	-	-	$5 \times I_{F,MAX}$		Pulse width = 2 s, $-40 \text{ }^\circ\text{C} \leq T_A \leq +85 \text{ }^\circ\text{C}$	-
$I_{R,TURN-OFF,MAX}$	Maximum Reverse Turn-Off Current (per rectifier)	-	-	$3 \times I_{F,MAX}$		$-40 \text{ }^\circ\text{C} \leq T_A \leq +85 \text{ }^\circ\text{C}$ , no loop inductance <sup>(7)</sup>	-
$L_{LOOP,MAX}$	Maximum Loop Inductance <sup>(7)</sup>	-	-	568	$\mu\text{H}$	Model DRM41A-xxx, Reverse Turn-Off Current = 100 A, $T_{cathode\_post} = +50 \text{ }^\circ\text{C}$	-
		-	-	193		Model DRM41A-xxx, Reverse Turn-Off Current = 150 A, $T_{cathode\_post} = +50 \text{ }^\circ\text{C}$	
		-	-	92		Model DRM41A-xxx, Reverse Turn-Off Current = 200 A, $T_{cathode\_post} = +50 \text{ }^\circ\text{C}$	
		-	-	52		Model DRM41A-xxx, Reverse Turn-Off Current = 250 A, $T_{cathode\_post} = +50 \text{ }^\circ\text{C}$	
		-	-	33		Model DRM41A-xxx, Reverse Turn-Off Current = 300 A, $T_{cathode\_post} = +50 \text{ }^\circ\text{C}$	
		-	-	115		Model DRM41B-xxx, Reverse Turn-Off Current = 100 A, $T_{cathode\_post} = +50 \text{ }^\circ\text{C}$	
		-	-	18		Model DRM41B-xxx, Reverse Turn-Off Current = 150 A, $T_{cathode\_post} = +50 \text{ }^\circ\text{C}$	
		-	-	7.8		Model DRM41B-xxx, Reverse Turn-Off Current = 200 A, $T_{cathode\_post} = +50 \text{ }^\circ\text{C}$	
		-	-	3.4		Model DRM41B-xxx, Reverse Turn-Off Current = 250 A, $T_{cathode\_post} = +50 \text{ }^\circ\text{C}$	
-	-	1	Model DRM41B-xxx, Reverse Turn-Off Current = 300 A, $T_{cathode\_post} = +50 \text{ }^\circ\text{C}$				
$V_F$	Forward Voltage Drop <sup>(8)</sup>	-	30	-	mV	DRM41A-100, Forward Current = $I_{F,MAX}$	-
		-	42	45		DRM41A-100, Forward Current = $I_{F,MAX}$ , $T_A = +85 \text{ }^\circ\text{C}$	
		-	34	-		DRM41A-150, Forward Current = $I_{F,MAX}$	
		-	46	49		DRM41A-150, Forward Current = $I_{F,MAX}$ , $T_A = +85 \text{ }^\circ\text{C}$	
		-	34	-		DRM41A-200, Forward Current = $I_{F,MAX}$	
		-	45	48		DRM41A-200, Forward Current = $I_{F,MAX}$ , $T_A = +85 \text{ }^\circ\text{C}$	
		-	36	-		DRM41A-250, Forward Current = $I_{F,MAX}$	
		-	48	51		DRM41A-250, Forward Current = $I_{F,MAX}$ , $T_A = +85 \text{ }^\circ\text{C}$	
		-	41	-		DRM41A-300, Forward Current = $I_{F,MAX}$	
		-	53	56		DRM41A-300, Forward Current = $I_{F,MAX}$ , $T_A = +85 \text{ }^\circ\text{C}$	
		-	33	-		DRM41B-100, Forward Current = $I_{F,MAX}$	
		-	48	51		DRM41B-100, Forward Current = $I_{F,MAX}$ , $T_A = +85 \text{ }^\circ\text{C}$	
		-	31	-		DRM41B-150, Forward Current = $I_{F,MAX}$	
		-	45	48		DRM41B-150, Forward Current = $I_{F,MAX}$ , $T_A = +85 \text{ }^\circ\text{C}$	
		-	38	-		DRM41B-200, Forward Current = $I_{F,MAX}$	
		-	55	58		DRM41B-200, Forward Current = $I_{F,MAX}$ , $T_A = +85 \text{ }^\circ\text{C}$	
		-	45	-		DRM41B-250, Forward Current = $I_{F,MAX}$	
		-	65	68		DRM41B-250, Forward Current = $I_{F,MAX}$ , $T_A = +85 \text{ }^\circ\text{C}$	
		-	49	-		DRM41B-300, Forward Current = $I_{F,MAX}$	
		-	72	76		DRM41B-300, Forward Current = $I_{F,MAX}$ , $T_A = +85 \text{ }^\circ\text{C}$	
$I_{over,trip}$	Forward Over-current Indicator Trip	-	$1.2 \times I_{F,MAX}$	-	A	$-40 \text{ }^\circ\text{C} \leq T_A \leq +85 \text{ }^\circ\text{C}$	-
$I_{over,reset}$	Forward Over-current Indicator Reset	-	$I_{over,trip} - 10$	-	A	$-40 \text{ }^\circ\text{C} \leq T_A \leq +85 \text{ }^\circ\text{C}$	-
$I_S$	Operating Current <sup>(9)</sup>	-	0.8	-	mA	$V_{K,main} = V_{K,aux} = 5.5 \text{ V}$ , Anode floating, $V_{IGN} = V_{STARTER} = 0 \text{ V}$ , Combine not active	1
		-	1.0	-		$V_{K,main} = V_{K,aux} = 12.0 \text{ V}$ , Anode floating, $V_{IGN} = V_{STARTER} = 0 \text{ V}$ , Combine not active	
		-	1.1	-		$V_{K,main} = V_{K,aux} = 18.0 \text{ V}$ , Anode floating, $V_{IGN} = V_{STARTER} = 0 \text{ V}$ , Combine not active	
		-	1.3	-		Models DRM41B-xxx, $V_{K,main} = V_{K,aux} = 24.0 \text{ V}$ , Anode floating, $V_{IGN} = V_{STARTER} = 0 \text{ V}$ , Combine not active	
		-	1.5	-		Models DRM41B-100 and DRM41B-150, $V_{K,main} = V_{K,aux} = 36.0 \text{ V}$ , Anode floating, $V_{IGN} = V_{STARTER} = 0 \text{ V}$ , Combine not active	
		-	1.7	-		Models DRM41B-200, DRM41B-250, and DRM41B-300, $V_{K,main} = V_{K,aux} = 36.0 \text{ V}$ , Anode floating, $V_{IGN} = V_{STARTER} = 0 \text{ V}$ , Combine not active	
		-	39	-		$V_A = 5.5 \text{ V}$ , Cathodes floating, $V_{IGN} = V_{STARTER} = 0 \text{ V}$ , Combine not active	
		-	40	-		$V_A = 12.0 \text{ V}$ , Cathodes floating, $V_{IGN} = V_{STARTER} = 0 \text{ V}$ , Combine not active	
		-	41	-		$V_A = 18.0 \text{ V}$ , Cathodes floating, $V_{IGN} = V_{STARTER} = 0 \text{ V}$ , Combine not active	
		-	41	-		Models DRM41B-xxx, $V_A = 24.0 \text{ V}$ , Cathodes floating, $V_{IGN} = V_{STARTER} = 0 \text{ V}$ , Combine not active	
-	43	-	Models DRM41B-xxx, $V_A = 36.0 \text{ V}$ , Cathodes floating, $V_{IGN} = V_{STARTER} = 0 \text{ V}$ , Combine not active				
-	66	-	Models DRM41A-xxx, $V_{K,x} = 12.0 \text{ V}$ , Anode and other cathode floating, Combine active (COMBINE+ and COMBINE- shorted)	3			
-	68	-	Models DRM41B-xxx, $V_{K,x} = 24.0 \text{ V}$ , Anode and other cathode floating, Combine active (COMBINE+ and COMBINE- shorted)				

Continued on next page...

**ELECTRICAL SPECIFICATIONS (continued)**

All devices ("x" = don't care), all amperages DC, all voltages DC and referenced to ground,  
 $T_A = +25 \pm 3 \text{ }^\circ\text{C}$ ,  $5.6 \text{ V} \leq V_A$  (DRM41A-xxx)  $\leq 18 \text{ V}$ ,  $5.6 \text{ V} \leq V_A$  (DRM41B-xxx)  $\leq 36 \text{ V}$ , all LEDs enabled, unless otherwise specified.

Symbol	Parameter	Min.	Typ.	Max.	Units	Conditions	Test Setup Figure
$I_R$	Reverse Leakage Current (per rectifier)	-	-	10	$\mu\text{A}$	$V_{Kx} = 5.5 \text{ V}$ , $V_A = 0 \text{ V}$	4
		-	-	20		$V_{Kx} = 12.0 \text{ V}$ , $V_A = 0 \text{ V}$	
		-	-	20		Models DRM41A-100, DRM41A-150, and DRM41B-xxx, $V_{Kx} = 18.0 \text{ V}$ , $V_A = 0 \text{ V}$	
		-	-	65		Models DRM41A-200, DRM41A-250, and DRM41A-300, $V_{Kx} = 18.0 \text{ V}$ , $V_A = 0 \text{ V}$	
		-	-	10		Models DRM41B-100 and DRM41B-150, $V_{Kx} = 24.0 \text{ V}$ , $V_A = 0 \text{ V}$	
		-	-	45		Models DRM41B-200, DRM41B-250, and DRM41B-300 $V_{Kx} = 24.0 \text{ V}$ , $V_A = 0 \text{ V}$	
		-	-	20		Models DRM41B-100 and DRM41B-150, $V_{Kx} = 36.0 \text{ V}$ , $V_A = 0 \text{ V}$	
		-	-	350		Models DRM41B-200, DRM41B-250, and DRM41B-300 $V_{Kx} = 36.0 \text{ V}$ , $V_A = 0 \text{ V}$	
$V_{IGN,ON}$	Ignition Alternator Excitation Trigger On Voltage <sup>(10)</sup>	-	2	-	V		5
$V_{IGN,OFF}$	Ignition Alternator Excitation Trigger Off Voltage <sup>(11)</sup>	-	$V_{IGN,ON} - 0.02$	-	V		
$V_{STARTER,TRIP}$	Starter Alternator Excitation Trigger Trip Voltage <sup>(12)</sup>	-	2	-	V		6
$V_{STARTER,GO}$	Starter Alternator Excitation Trigger Go Voltage <sup>(12)</sup>	-	$V_{STARTER,GO} - 0.02$	-	V		
$I_{IGN}$	Ignition Alternator Excitation Trigger Current	-	25	-	$\mu\text{A}$	$V_{IGN} = 5.0 \text{ V}$	7
		-	61	-		$V_{IGN} = 12.0 \text{ V}$	
		-	112	-		$V_{IGN} = 18.0 \text{ V}$	
		-	173	-		$V_{IGN} = 24.0 \text{ V}$	
		-	294	-		$V_{IGN} = 36.0 \text{ V}$	
$I_{STARTER}$	Starter Alternator Excitation Trigger Current	-	50	-	$\mu\text{A}$	$V_{STARTER} = 5.0 \text{ V}$	8
		-	121	-		$V_{STARTER} = 12.0 \text{ V}$	
		-	223	-		$V_{STARTER} = 18.0 \text{ V}$	
		-	344	-		$V_{STARTER} = 24.0 \text{ V}$	
		-	585	-		$V_{STARTER} = 36.0 \text{ V}$	
$t_{ALTEXC,DELAY}$	Alternator Excitation Delay Time <sup>(13)</sup>	-	4	-	s		-
$t_{ALTEXC,PULSEON}$	Alternator Excitation Pulse On Time <sup>(13)</sup>	-	0.5	-	s		-
$t_{ALTEXC,PULSEOFF}$	Alternator Excitation Pulse Off Time <sup>(13)</sup>	-	0.5	-	s		-
-	Number of Alternator Excitation Pulses <sup>(13)</sup>	-	-	60			-
$I_{COMBINE}$	Combine Trigger Current	-	33	-	$\mu\text{A}$	COMBINE+ and COMBINE- shorted together	9
$V_{COMBINE+}$	COMBINE+ Floating Voltage	-	3.3	-	V		-
$t_{RR}$	Rectifier Reverse Recovery Time <sup>(14)</sup>	-	-	1.3	ms	Models DRM41A-xxx, $I_F = I_{SURGE,MAX}$	-
		-	-	1.5		Models DRM41B-xxx, $I_F = I_{SURGE,MAX}$	
$t_{MOSFET,START}$	MOSFET Start-up Time <sup>(15)</sup>	-	130	-	ms	$V_A = 0$ to $12 \text{ V}$ , Cathodes floating	-
		-	-	5		$V_{Kx} = 14 \text{ V}$ to floating, $V_A = 12 \text{ V}$	

**Notes:**

- Stresses beyond those listed under absolute maximum ratings may cause permanent damage to the device. Exposure to any absolute maximum rating condition for extended periods may affect device reliability and lifetime.
- Valid when  $-21 \text{ V} \leq V_K \leq 0 \text{ V}$  ( $-39 \text{ V} \leq V_K \leq 0 \text{ V}$ ) for model DRM41A-xxx (DRM41B-xxx) or if cathode terminals are floating. If  $V_K > 0 \text{ V}$ , minimum anode voltage is  $V_K - 21 \text{ V}$  ( $V_K - 39 \text{ V}$ ) for model DRM41A-xxx (DRM41B-xxx). Conditions must be adhered to for both cathodes.
- Transient-protected to 40 V. Additional external protection may be required in some applications.
- Transient-protected to 60 V. Additional external protection may be required in some applications.
- Using the rectifier with the device ground disconnected is not recommended. Exceeding any of these ratings will cause excessive heat buildup, leading to MOSFET failure.
- Transient-protected to -60 V. Additional external protection may be required in some applications.
- Loop inductances are defined as the external system inductance seen between the common anode and either cathode. See application sheet for further information.
- Voltage drop tested under pulsed conditions with pulse length  $\leq 2 \text{ s}$ .
- $I_S$  sourced from cathode (anode), when  $V_A < V_K$  ( $V_A > V_K$ ).
- Ignition alternator excitation trigger on voltage defined as the ignition line voltage at which the alternator excitation process begins. Voltage must stay above this value during entire excitation process.
- Ignition alternator excitation trigger off voltage defined as the ignition line voltage at which the alternator excitation process is terminated and reset; voltage must rise above the ignition alternator trigger on voltage to restart the alternator excitation process.
- Starter alternator excitation trigger trip voltage is defined as the rising starter line voltage at which the device detects a start event. Starter alternator excitation trigger go voltage is defined as the falling starter line voltage at which the alternator excitation process begins (after the voltage has first risen above  $V_{STARTER,TRIP}$ ). If at any time during the alternator excitation process the starter line voltage rises above  $V_{STARTER,TRIP}$ , the alternator excitation process will be terminated and the device will wait for the voltage to fall below  $V_{STARTER,GO}$  before initiating a new alternator excitation process.
- See application sheet for more information on the alternator excitation process.
- Reverse recovery time measured from the time the anode-to-cathode voltage goes negative until the MOSFET array turns completely off. Reverse current may continue to flow through the MOSFET transient voltage suppression diodes or the inductive load diode depending on the inductance in the system.
- MOSFET start-up time is defined as the time from when  $V_A - V_K$  becomes positive to when the MOSFETs enter their low-resistance state.

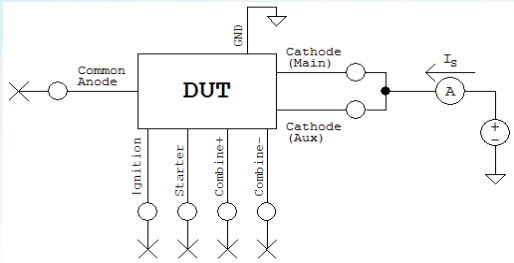

Figure 1: Operating Current ( $V_K > V_A$ )

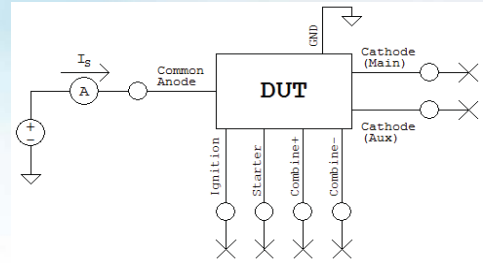

Figure 2: Operating Current ( $V_A > V_K$ )

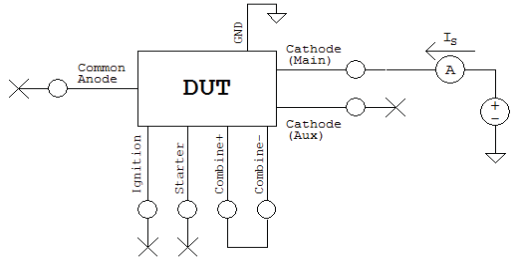

Figure 3: Operating Current (Combine Mode Active)

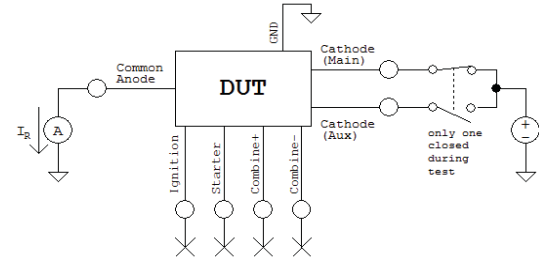

Figure 4: Reverse Leakage Current

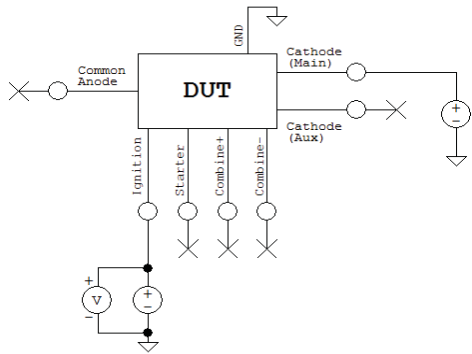

Figure 5: Ignition Alternator Excitation Voltage

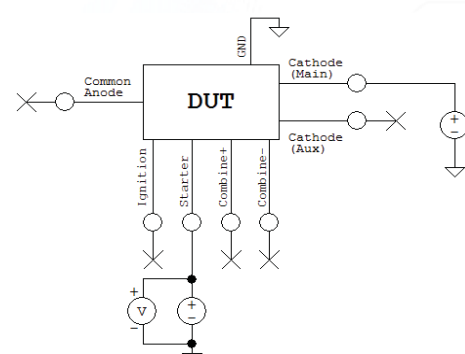

Figure 6: Starter Alternator Excitation Voltage

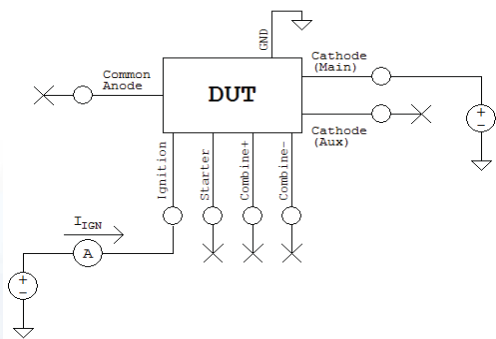

Figure 7: Ignition Alternator Excitation Current

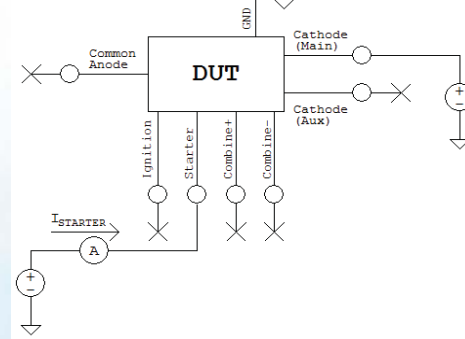

Figure 8: Starter Alternator Excitation Current

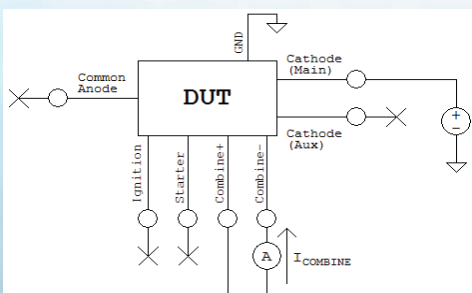
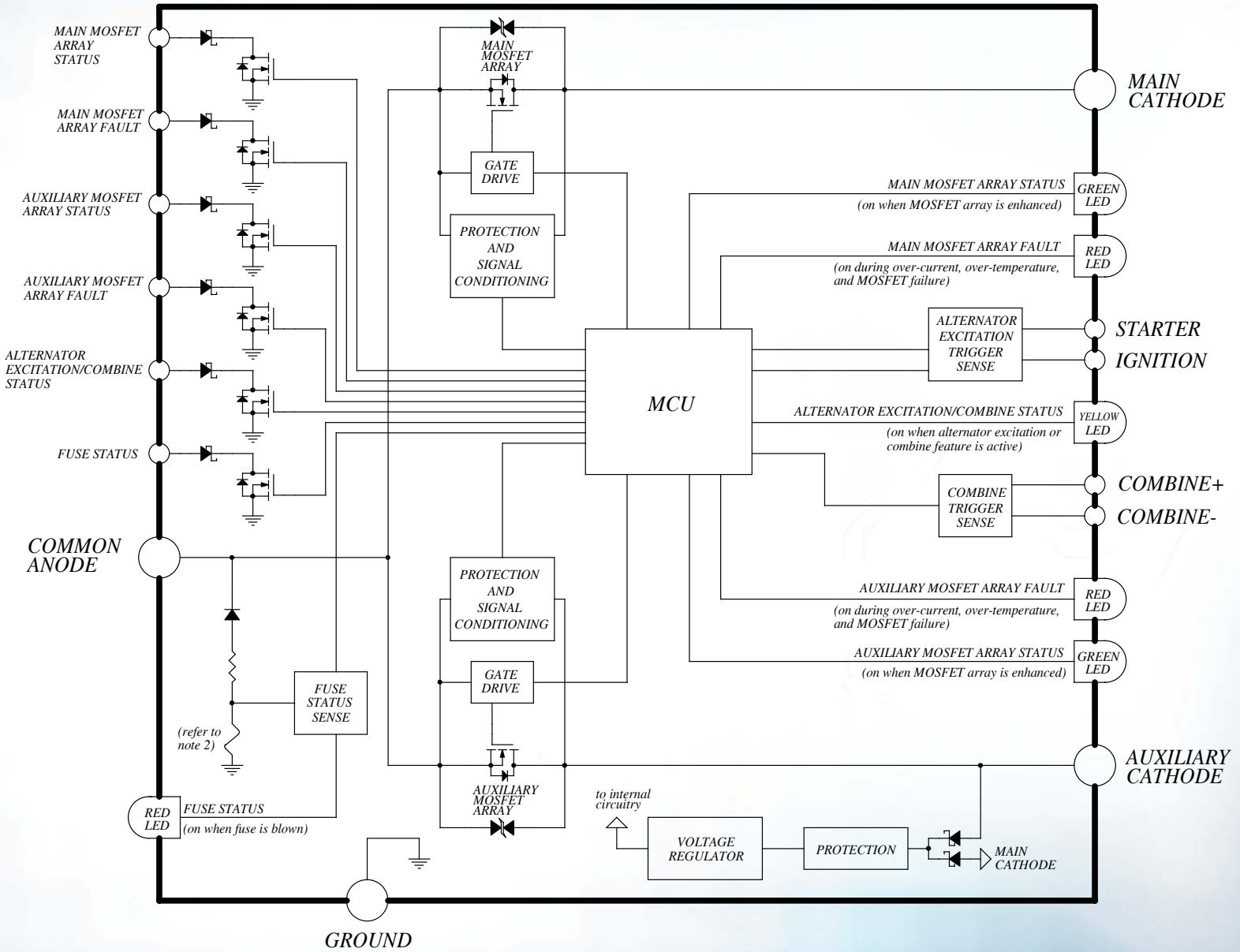
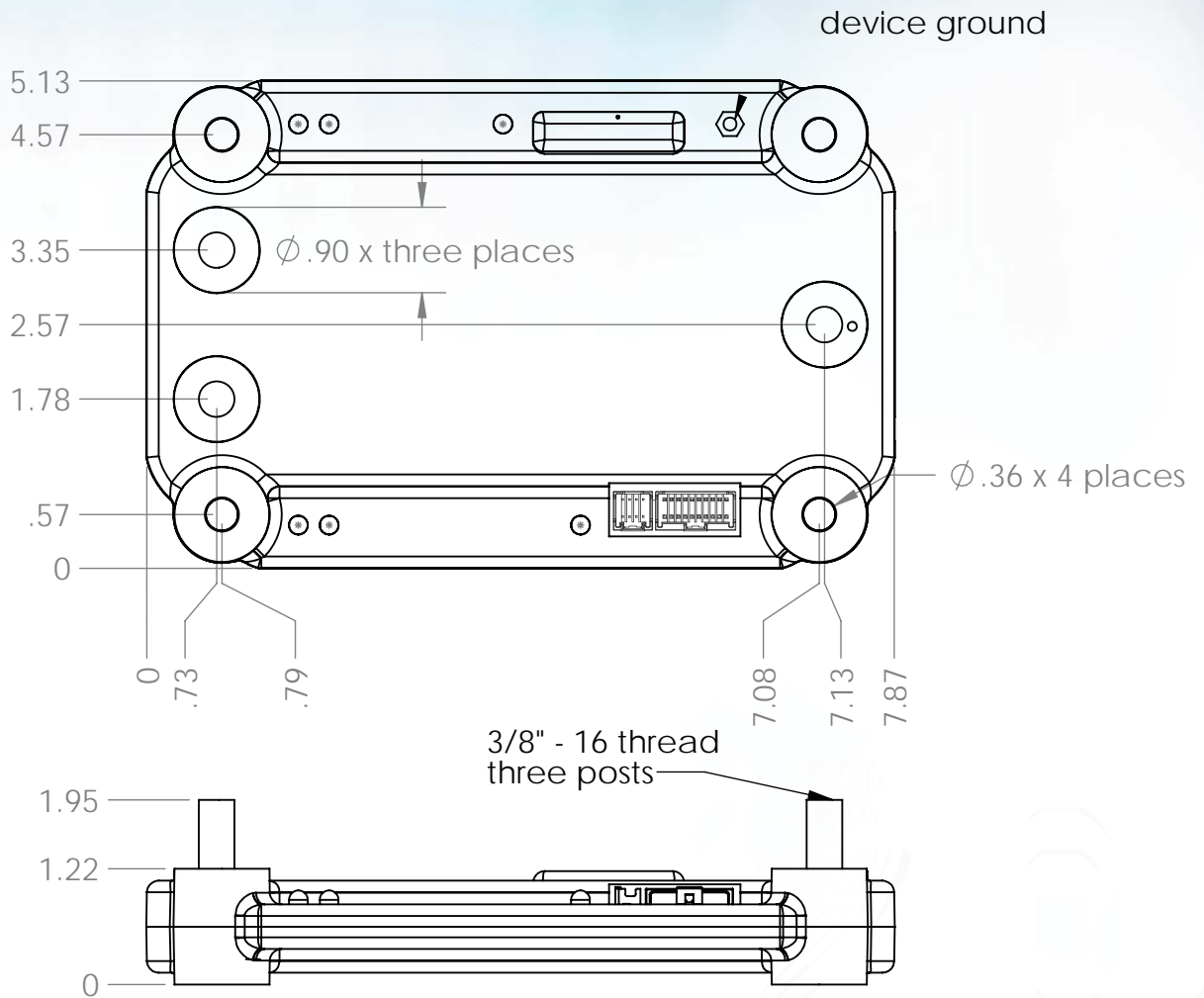

Figure 9: Combine trigger current

FUNCTIONAL BLOCK DIAGRAM





Electronic assembly inserted into polycarbonate enclosure and fully encapsulated with silicone elastomer specifically developed for potting electronic modules.

Four integrated mounting points for user supplied 5/16" mounting hardware of suitable length.

Brass mounting posts, 3/8 - 16 x .75" with provided brass washers and nylon insert nuts. Mounting torque not to exceed 15 newton-meters.

Molex top-mounted control harness and expansion port for remote monitoring display.

Typical weight post encapsulation including provided hardware is 23.5 ounces (+/- 10%)

**Diagram 1**

**POWER-GATE Dual Rectifier** allows all batteries in the network to be charged. In the diagram below, the alternator (or alternate charging source like DC shore power, solar array, or DC battery charger) is applying charging current to the anode (input) post of the rectifier. Current passes through two independent MOSFET arrays to Main Battery cathode and Auxiliary Battery cathode. Loads applied to the Auxiliary Battery are isolated from the Main Battery just as Main Battery loads are isolated from Auxiliary Battery.

The Orange alternator excitation circuit ensures that internally regulated alternators are energized by the downstream battery during the engine cranking process, a necessity when placing an isolator between the alternator and batteries.

The Battery Combine feature causes bi-directional current flow between the two batteries when the two "combine" wires are joined together. Should the Main Battery be discharged to a low, no-start condition, the Auxiliary Battery can be "jumped" to the Main Battery. The use of a momentary switch is recommended to ensure the battery combine feature is disabled by default.

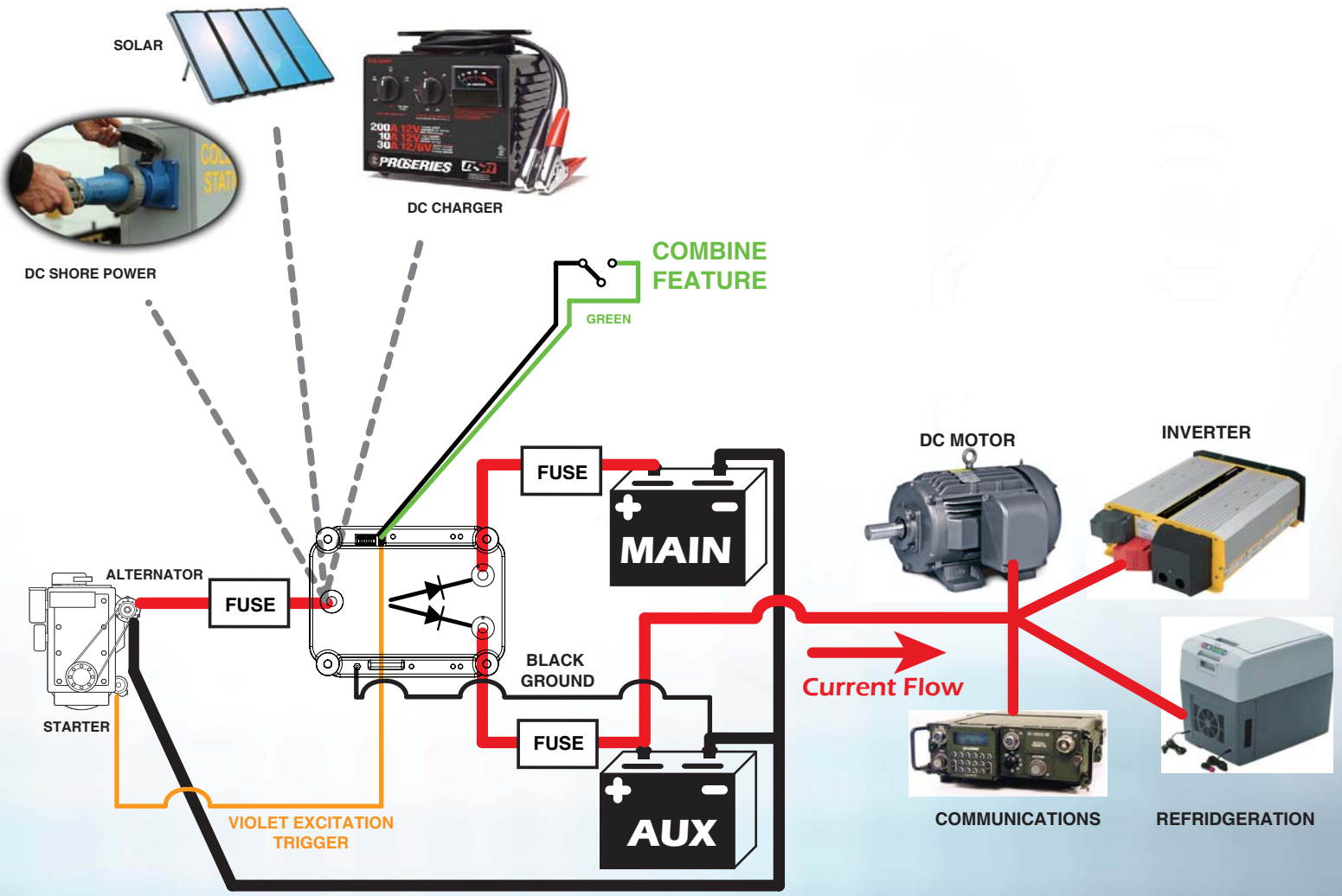

The manufacturer strongly recommends the use of remote-mounted visual indicators (LED or lamp) and/or audible indicators (alarm or buzzer) informing the driver of either normal operation or a fault condition. Should a fault condition occur, it is necessary to remove the Dual Rectifier from the electrical circuit and contact the manufacturer for diagnostic support or replacement.

Customer should match the LED / Lamp and/or alarm(s) to the voltage rating of the native electrical system. For example, a 12 volt vehicle will use a 12 volt Dual Rectifier with 12 volt LEDs and alarms. A 24 volt vehicle will use a 24 volt Dual Rectifier with 24 volt LEDs and alarms.

Current draw not to exceed 60mA

Wires coming from the connector are switched to ground when active, so the cathode of the LED should connect to the harness wire, and the anode should connect to the positive source voltage.

**6057 REV B DR-SR-RR Control Harness, All Packages**

Connector housing Molex 051353-0800  
 Terminals Molex 56134-9000  
 Control harness, two meters, 24 AWG wires, UL style 1007/1569  
 No strip on loose-wire end

1	Starter	Orange
2	Main Trigger + (not used for DR)	Red
3	Ignition	Violet
4	Empty	
5	Econo Trigger	Green
6	Empty	
7	Combine Trigger -	Brown
8	Combine Trigger +	Blue

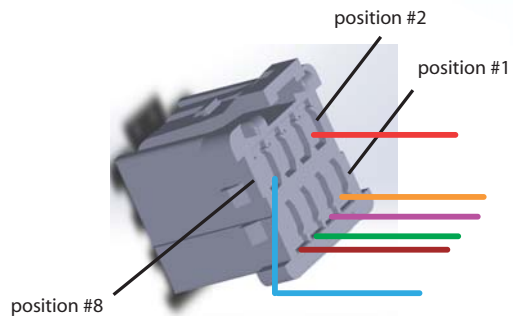

**Note to User: Depending on application, some wires shown may not be installed.**

**6050 Rev A DR 4.1 External LED Harness, All Packages**

Connector housing Molex 51353-1800  
 Terminals Molex 56134-9000  
 Control harness, three meters, 24 AWG wires, UL style 1007/1569  
 No strip on loose-wire end

1	Auxiliary Leg Status	Green
2	Empty	
3	Alternator Excite / Combine Active	Violet
4	Empty	
5	Main Leg Status	Yellow
6	Empty	
7	Empty	
8	Empty	
9	Auxiliary Leg Fault	Red
10	Empty	
11	Main Leg Fault	Orange
12-18	Empty	

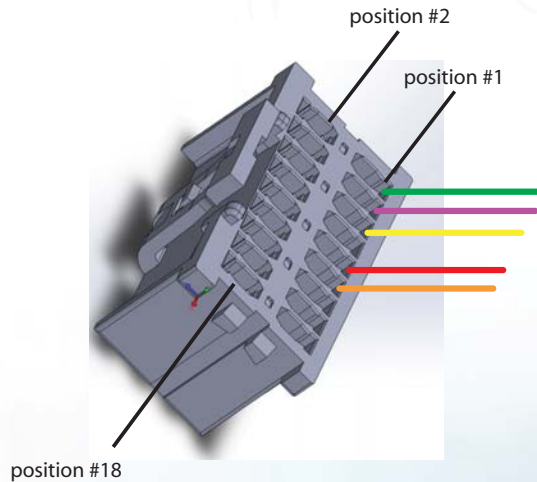

**Note to User: Depending on application, some wires shown may not be installed.**

