

# POWER-GATE™ Solid-State Devices

## Single Rectifier (ideal diode)

### Generation 4.0



**up to 600 Amps**  
**12 and 24 Volts**

#### APPLICATIONS:

An ideal diode designed to switch and control DC. Common uses include military, aeronautic, automotive, marine, industrial machinery, photovoltaic, fleet utility.

#### FEATURES and BENEFITS:

- Low voltage, high current capability
- Internationally patented arrayed MOSFET technology
- Optional MIL-STD-461E Compliant
- 99.9% efficiency at max. current
- High Surge Capability
- Fully Encapsulated solid state design
- Light weight
- Dramatically smaller than conventional devices
- Market-leading, ultra-low on-state resistance
- No heat sinks or airflow required
- No de-rating required over full temperature range
- Microcontroller programmable for custom options
- Quik-turn capability
- Recommended by top battery manufacturers

POWER-GATE Single Rectifier ideal diodes allow multiple batteries or banks to be charged from a single power source like an alternator or battery charger, and discharged independently. They can be used in dual battery systems to protect a starting battery from auxiliary battery discharge, or separation of battery banks can be achieved with each bank connected to its own cathode respectively.

For example, a vehicle may have one battery dedicated to the engine (ignition, starter, EFI, etc..) while the auxiliary or "house" battery is dedicated for auxiliary equipment (lights, inverter, computer, communications, etc..) With the vehicle running, all batteries get charged to the full voltage regulation setpoint of the alternator. With the engine off, the auxiliary battery loads (lights, inverter, computer, communications, etc..) will continue to operate and discharge the dedicated auxiliary battery. During the auxiliary battery discharge, the POWER-GATE will not allow current to pass from the main starting battery to feed the auxiliary battery loads.

Conventional silicon and Schottky rectifiers are attractively priced, but have significant performance issues:

- substantial voltage drop as current passes
- conductive losses create significant heat
- batteries never get fully charged
- alternator regulators always inaccurate due to diode drop

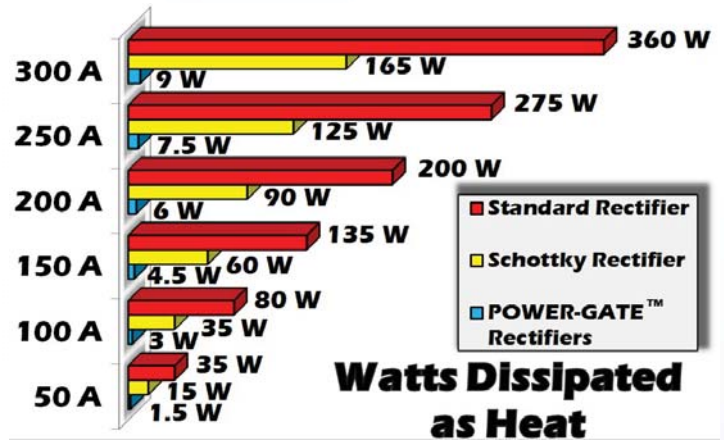

#### QUICK SPECIFICATIONS:

Current Rating:	100 to 600 amps
Operating Voltage:	7.5 to 36 VDC
Voltage Drop at Max Current:	30mV
Temperature Range:	-40 to +105 C
Dimensions	Small 6.33" x 4.31" x 1.80"
	Medium 7.87" x 5.13" x 1.95"
	Large 8.58" x 6.63" x 1.89"

See full Specification Sheet on our website.

#### PACKAGE CHARACTERISTICS:

Electronic assembly inserted into Polycarbonate encapsulation shell then backfilled with aerospace qualified silicon elastomer.

Four integrated mounting holes.

Brass mounting posts with provided brass washers and nylon insert nuts. Mounting torque not to exceed 75 inch-pounds or 8.5 newton-meters.

#### MECHANICAL SPECIFICATIONS

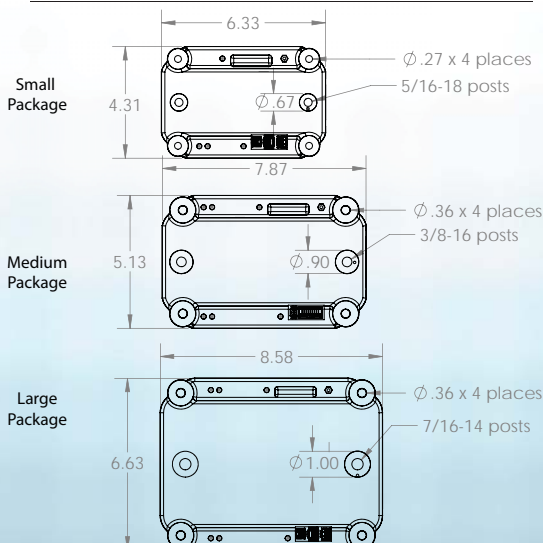

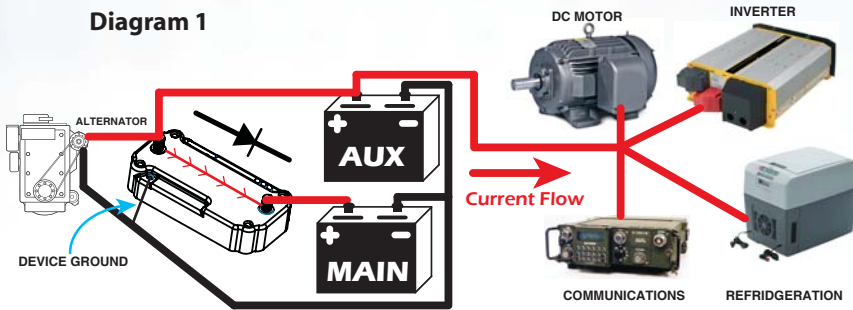

**POWER-GATE Single Rectifier Isolator** allows all batteries in the network to be charged. In Diagram 1, the alternator is charging the AUX battery which is common on the device input post, and current is flowing through the MOSFET array to the MAIN battery. All loads applied to both batteries are being powered. See Diagram 2 to see what happens when the AUX battery is discharged.

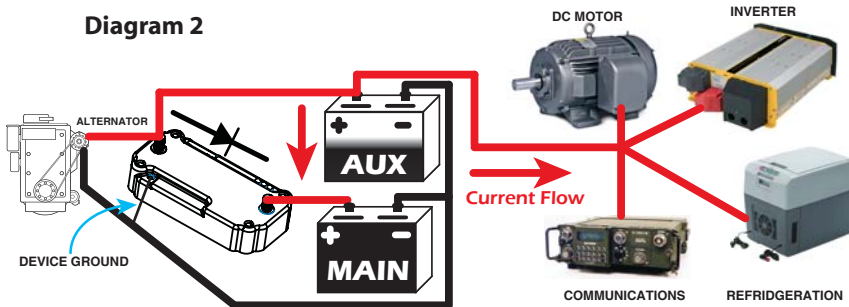

When the vehicle is off and load(s) are applied to the AUX battery, the AUX battery will discharge independent of the MAIN battery. Note the orientation of the diode symbol. The **POWER-GATE's** MOSFET array behaves like an "ideal" diode in that reverse current cannot flow from MAIN to AUX while forward current enjoys an absolute minimum voltage drop as denoted in Diagram 1.

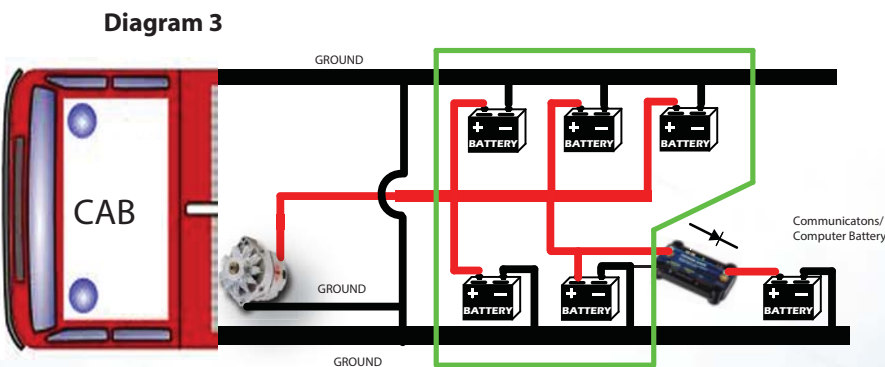

**POWER-GATE Single Rectifier Isolator** can be installed as an ideal diode. In Diagram 3, the Communications/Computer battery is isolated from the rest of the battery network. When the vehicle engine is cranked, the resulting dip in system voltage can cause the Communications and Computer equipment to reset. However, with the Comms/Computer battery isolated on its own dedicated cathode, when the system voltage dips, the Comm/Computer battery is automatically isolated alleviating wait-time needed for systems to reboot.

Under normal charging conditions either provided by the alternator or shore-power, all batteries charge as normal.

For OEM applications, military and fleet sales, special applications, custom configurations, or general questions, please contact us at (858) 720-1339