

# POWER-GATE™ Solid-State Devices

## Dual Rectifier **Generation 4.1**

### 400 A, 500A, 600 A



Made in U.S.A



POWER-GATE Dual Rectifiers allow dual batteries to be charged from a single power source like an alternator or battery charger, and discharge each battery (or bank) independently without drawing current from the opposing battery (or bank).

For example, a vehicle may have one battery dedicated to the engine (ignition, starter, EFI, etc..) while the auxiliary or “house” battery is dedicated for auxiliary equipment (lights, inverter, computer, communications, etc..) With the vehicle running, all batteries get charged to the full voltage regulation setpoint of the alternator. With the engine off, the auxiliary battery loads (lights, inverter, computer, communications, etc..) will continue to operate and discharge the dedicated auxiliary battery independent of the main battery. If a load is applied to the main battery, current draw will be limited to the main battery and not pass from the auxiliary battery.

#### APPLICATIONS:

An ideal dual diode designed to switch and control DC. Common uses include military, aeronautic, automotive, marine, industrial machinery, photovoltaic, fleet utility.

#### FEATURES and BENEFITS:

- Highest amperage isolator available on the market
- Market-leading, ultra-low on-state resistance
- Low voltage, high current capability
- Internationally patented arrayed MOSFET technology
- 100% solid state, no moving parts to wear
- 99.9% efficiency at max. current
- No heat sinks or airflow required
- No de-rating required over full temperature range
- Battery combine feature for self-jumping
- Fully encapsulated rough-duty design
- 7/16-14 x .75" brass studs accommodate large cabling
- CNC cut and plated internal conductors
- Expansion port for external monitoring display
- On-board LED's providing visual feedback
- High surge capability
- MIL-STD-461E Compliant
- Quik-turn capability
- Recommended by top battery manufacturers

Conventional silicon and Schottky rectifiers are attractively priced, but have significant performance issues:

- substantial voltage drop as current passes
- conductive losses create significant heat
- constructed on large heat sinks requiring airflow and thermal bonding to chassis for cooling purposes
- batteries never get fully charged
- alternator regulators always inaccurate due to diode drop
- limited current capability before thermal failure

POWER-GATE Dual Rectifiers utilize state-of-the-art MOSFET architecture eliminating performance and reliability issues typical of dated silicon and Schottky isolators.

#### QUICK SPECIFICATIONS:

Current Rating:	400 to 600 amps
Surge Current:	up to 3,000 amps
Operating Voltage:	
12v Device	6 to 18 VDC
24v Device	6 to 36 VDC
Voltage Drop at Max Current:	
12v Device	39 to 51 mV *
24v Device	44 to 59 mV *

Temperature Range:	-40 to +85 C
Weight:	54 ounces
Dimensions	8.58" x 6.63" x 1.89"

\* Specific current rating of device and ambient temperature dependant. See full Specification Sheet on our website.

#### PACKAGE CHARACTERISTICS:

Electronic assembly inserted into hi-temp polycarbonate enclosure and fully encapsulated with silicone elastomer specifically developed for potting electronic modules.

Four integrated mounting points for user supplied 5/16" mounting hardware of suitable length.

Brass mounting posts, 7/16-14 x .75" with provided brass washers and nylon insert nuts. Mounting torque not to exceed 15 newton-meters.

Molex top-mounted control harness and expansion port for remote monitoring display.

Perfect Switch, LLC  
(858) 720-1339

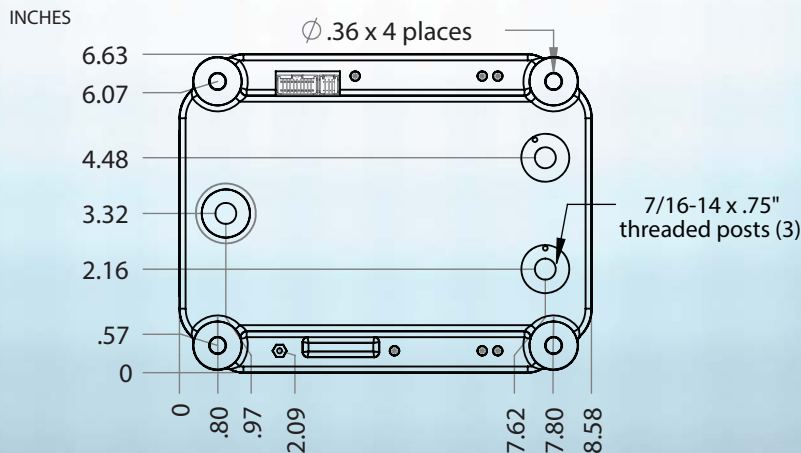
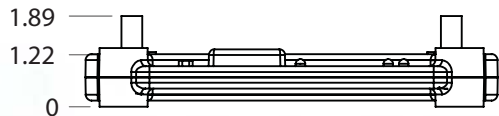

**POWER-GATE Dual Rectifier** allows all batteries in the network to be charged. In the diagram below, the alternator (or alternate charging source like DC shore power, solar array, or DC battery charger) is applying charging current to the anode (input) post of the rectifier. Current passes through two independent MOSFET arrays to Main Battery cathode and Auxiliary Battery cathode. Loads applied to the Auxiliary Battery are isolated from the Main Battery just as Main Battery loads are isolated from Auxiliary Battery.

The Violet alternator excitation circuit ensures that internally regulated alternators are energized by the downstream battery during the engine cranking process, a necessity when placing an isolator between the alternator and the batteries.

The Battery Combine feature causes bi-directional current flow between the two batteries when the two “combine” wires are joined together. Should the Main Battery be discharged to a low, no-start condition, the Auxiliary Battery can be “jumped” to the Main Battery. The use of a momentary switch is recommended to ensure the battery combine feature is disabled by default.

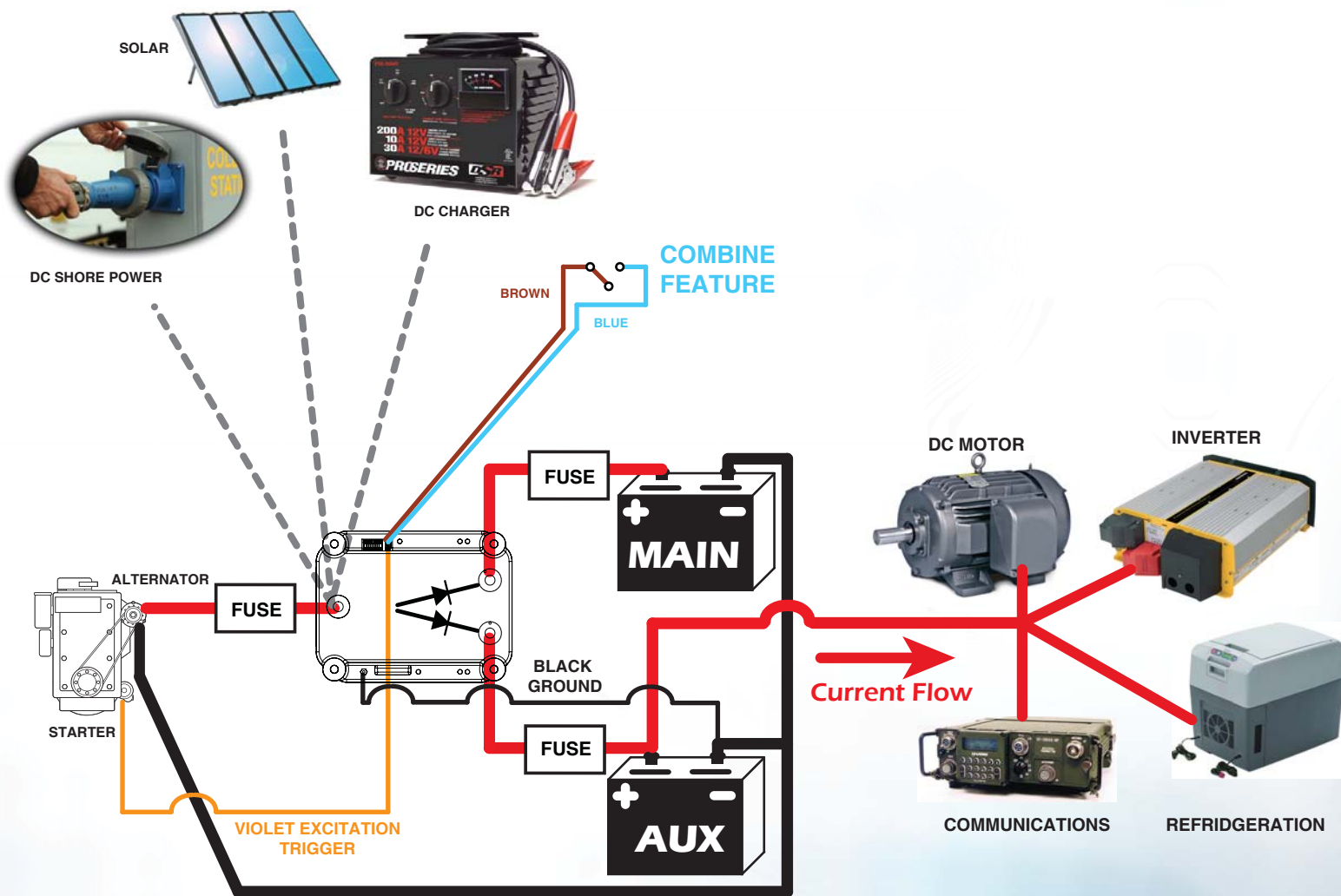

For OEM applications, military and fleet sales, special applications, custom configurations, or general questions, please contact us at (858) 720-1339